

Auszugsvorrichtung

Extraction units

BITO
WWW.BITO.COM

#10/2017/Art.-Nr.: 16454

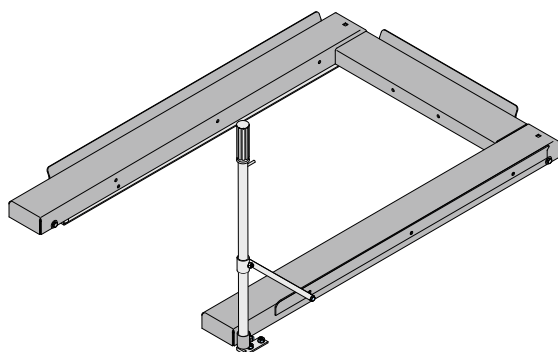

#33195 - 800 kg
#33196 - 1000 kg

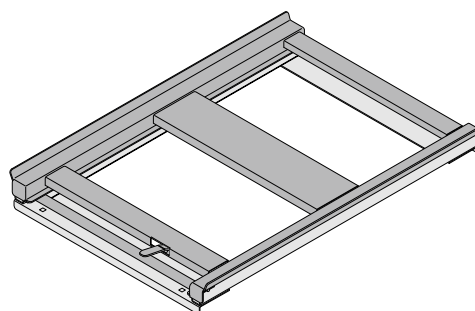

#33200 - 600 kg
#33201 - 800 kg

QR-Code



Aufbau- und Bedienanleitung (DE)
Instructions for assembly and use (GB)
Instructions de montage et d'utilisation (FR)
Richtlijnen en montagehandleiding (BE)
Instrucciones de montaje y manejo (ES)
Istruzioni per il montaggio e l'impiego (IT)
Montage- op betjeningsvejledning (DK)
összeállítási és kezelési útmutató (HU)
Instrukcja montażu i użytkowania (PL)
Návod k montáži a obsluze (CZ)
Návod na montáž a použitie (SK)
Інструкція по монтажу та експлуатації (UA)
Инструкция по сборке и использованию (RU)



www.bitto.com

#33195 - 800 kg

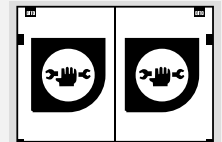
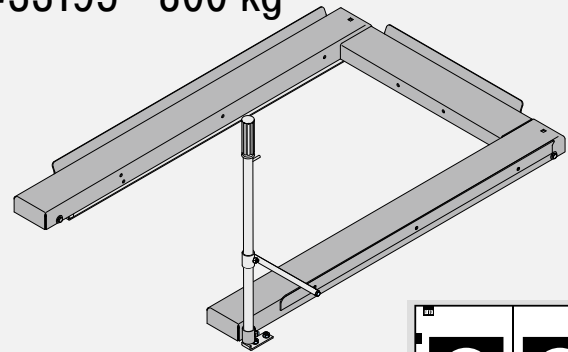
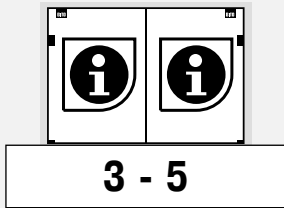

6 - 11,
17

#33196 - 1000 kg

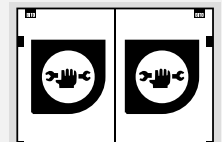
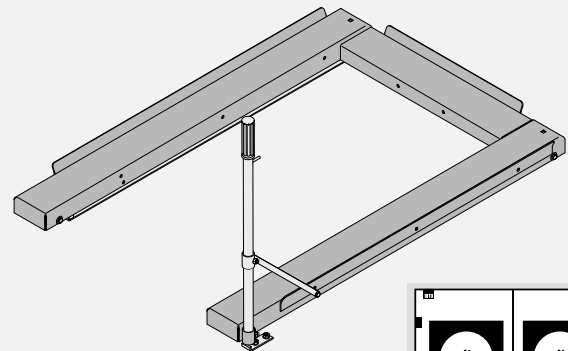
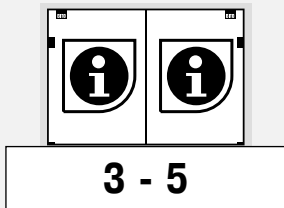

12 - 17

#33200 - 600 kg
#33201 - 800 kg

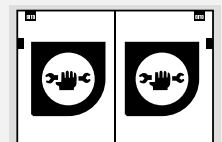
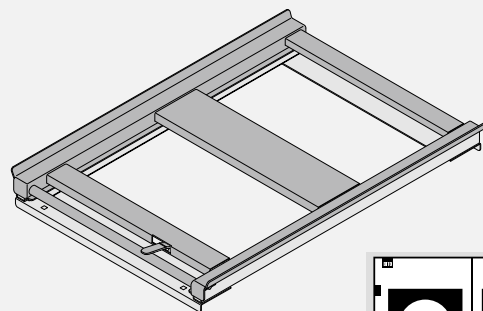
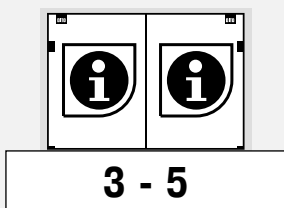

18 - 23

DIN EN 15620
DIN EN 15635
DIN EN 15629

BGR 234

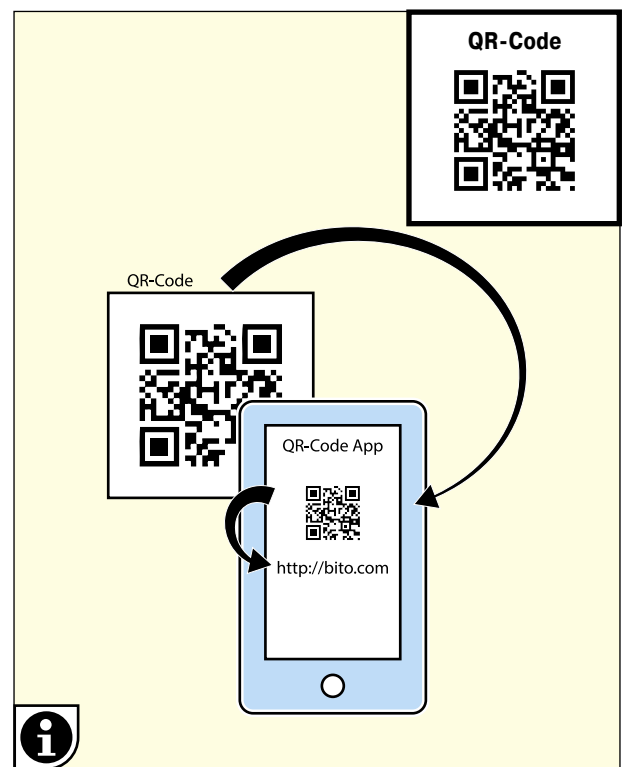
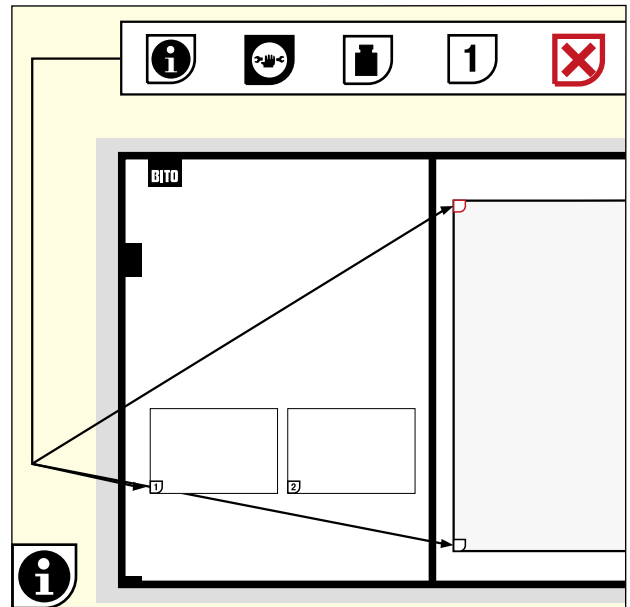
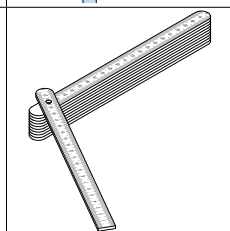
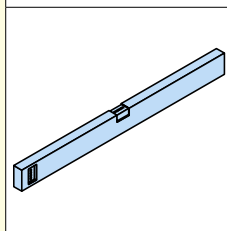
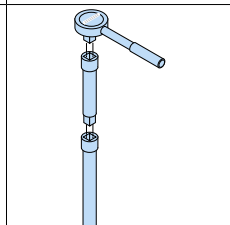
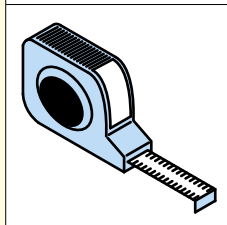
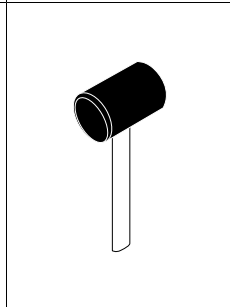
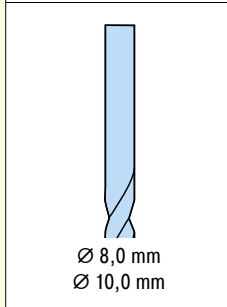
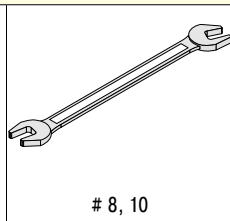
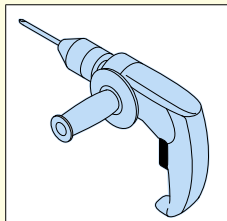
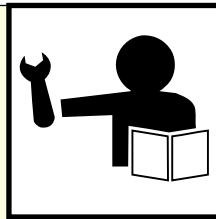
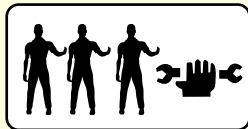

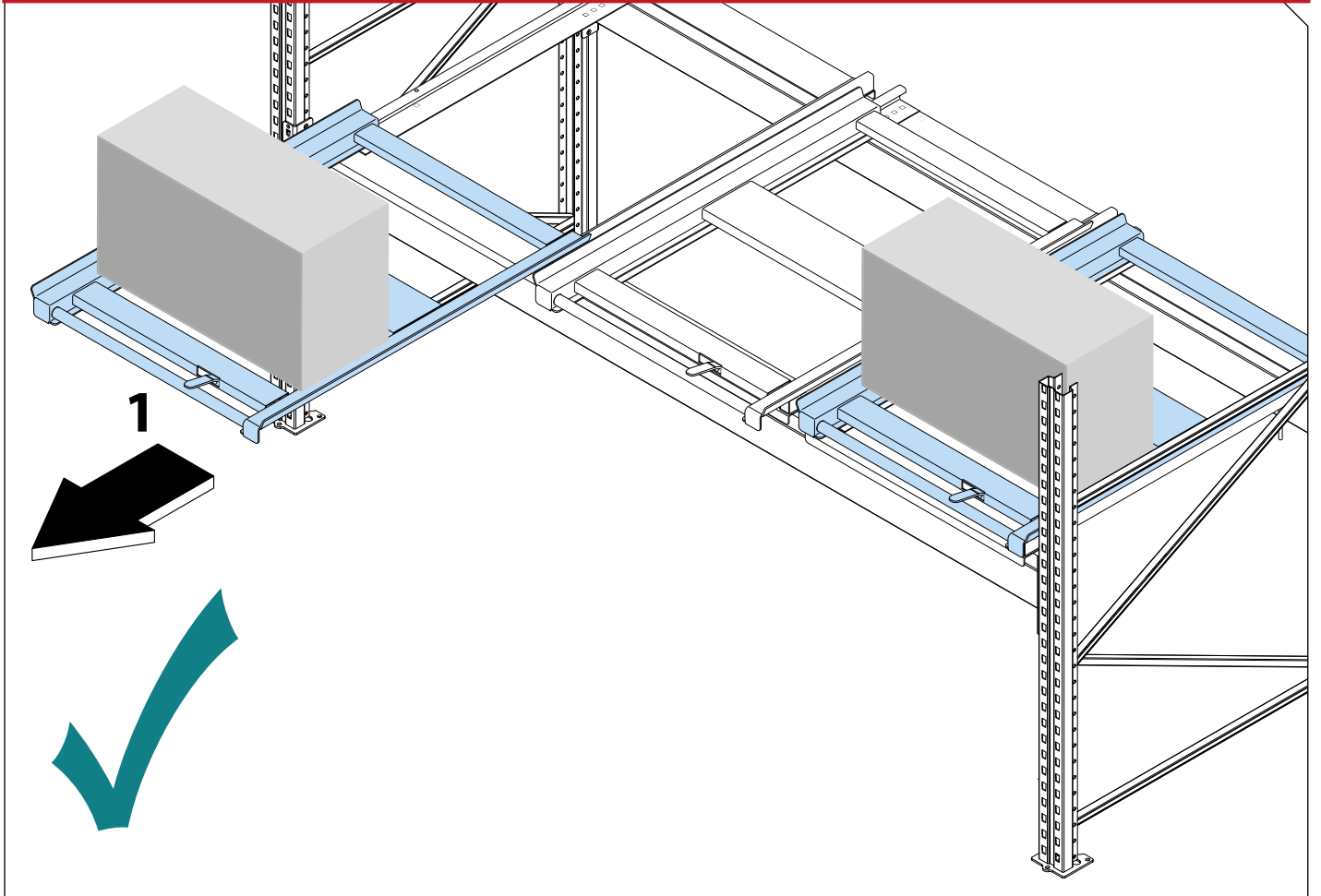
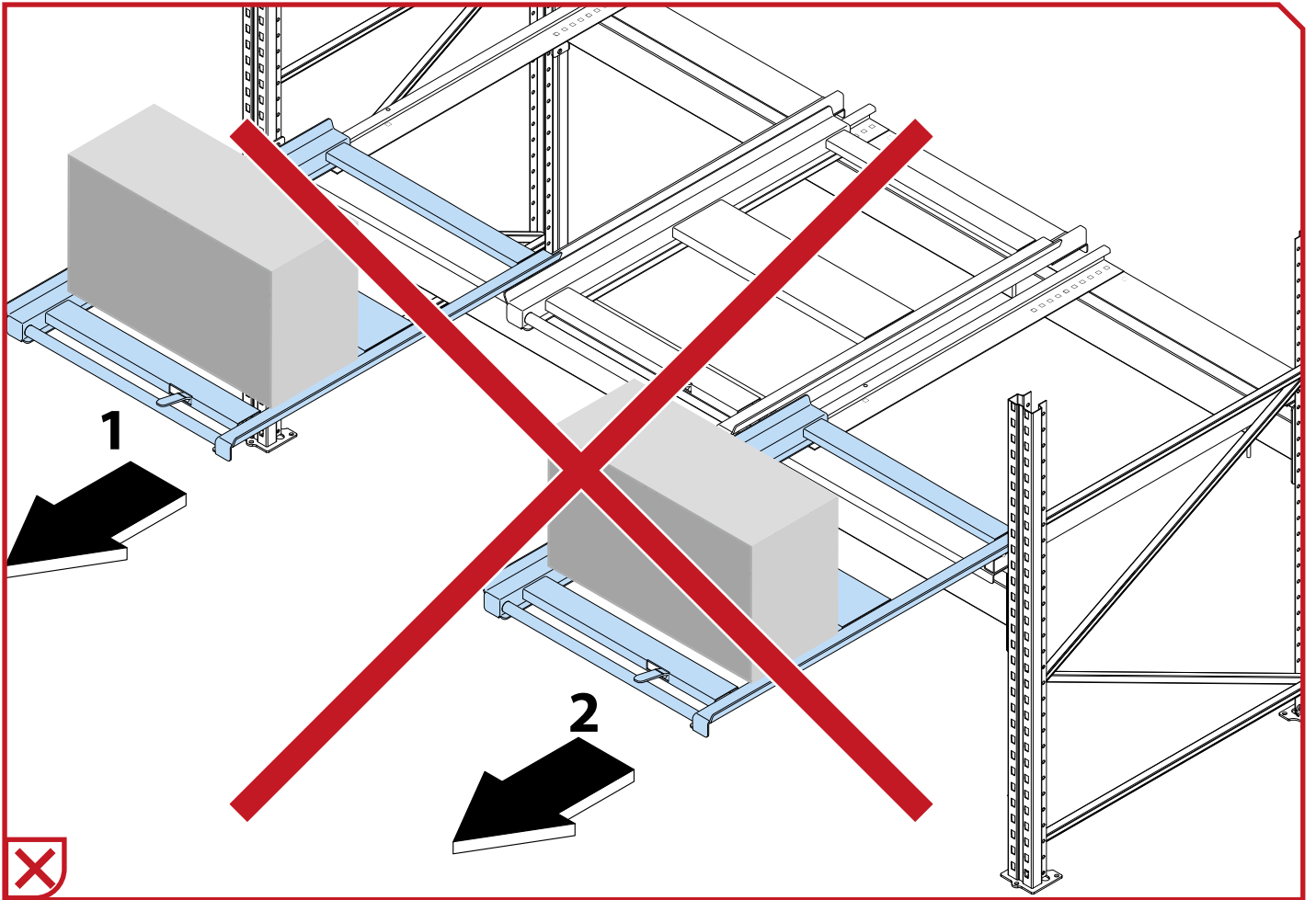

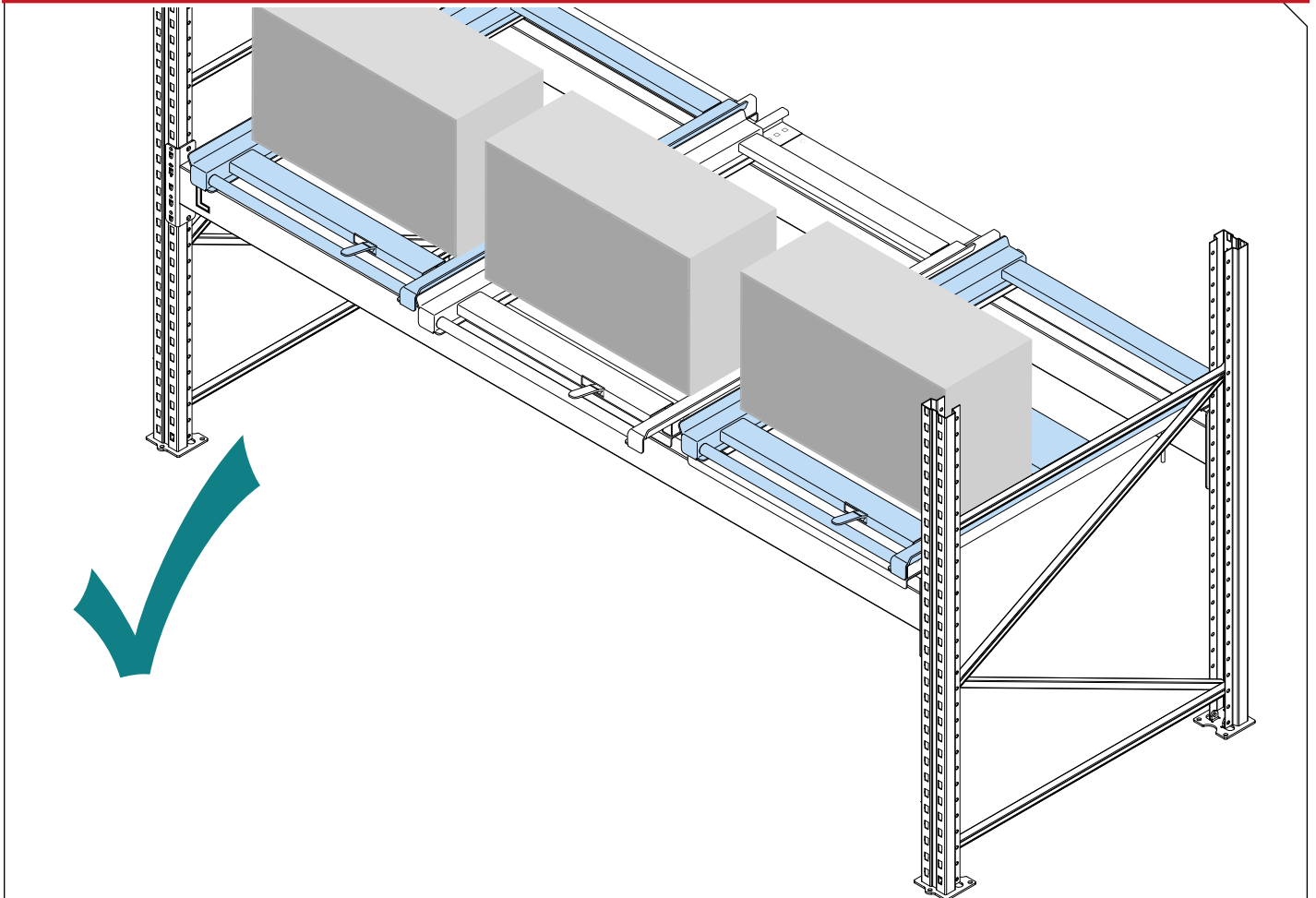
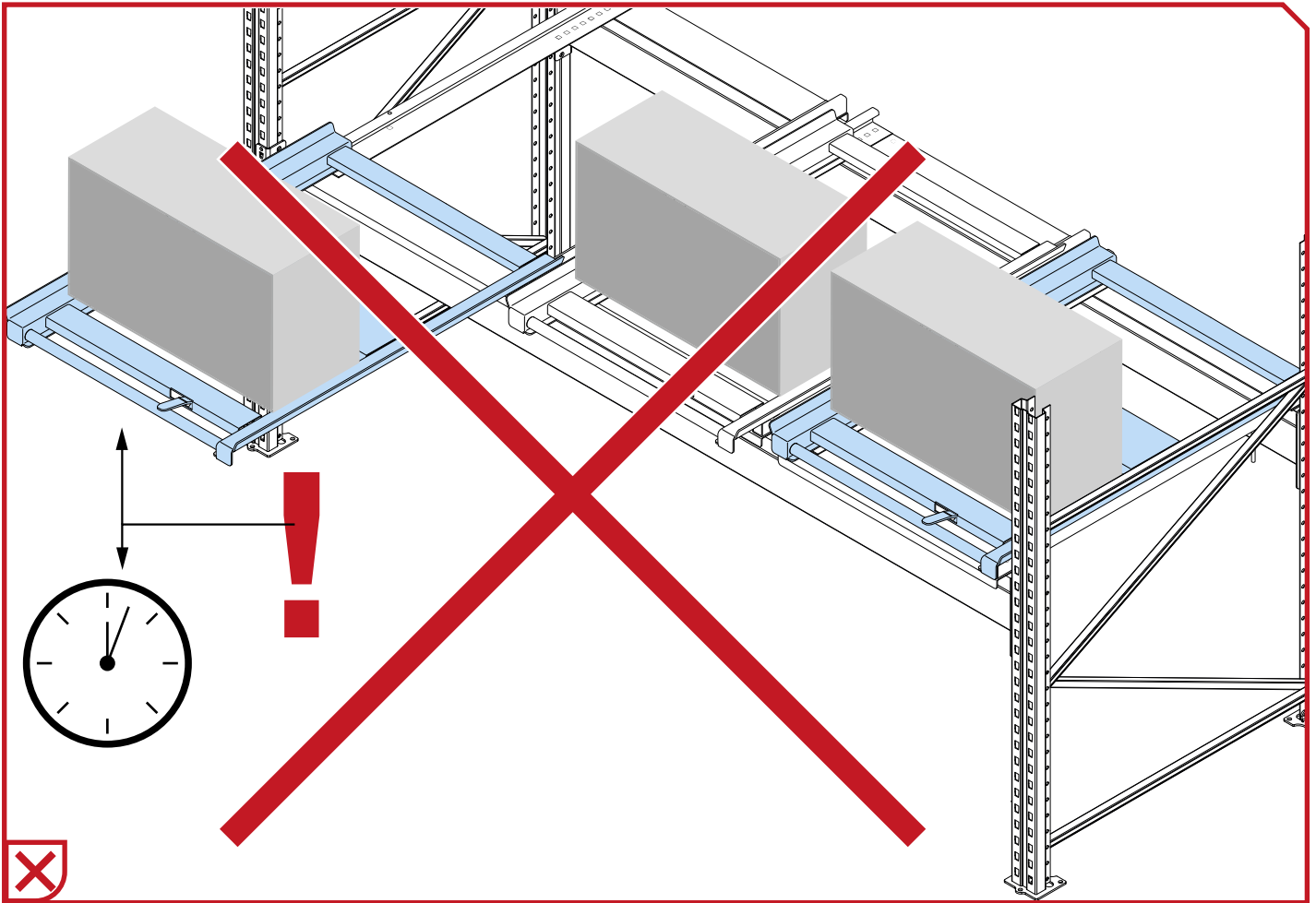

Auszugsvorrichtung

Extraction units

#33195 - 800 kg

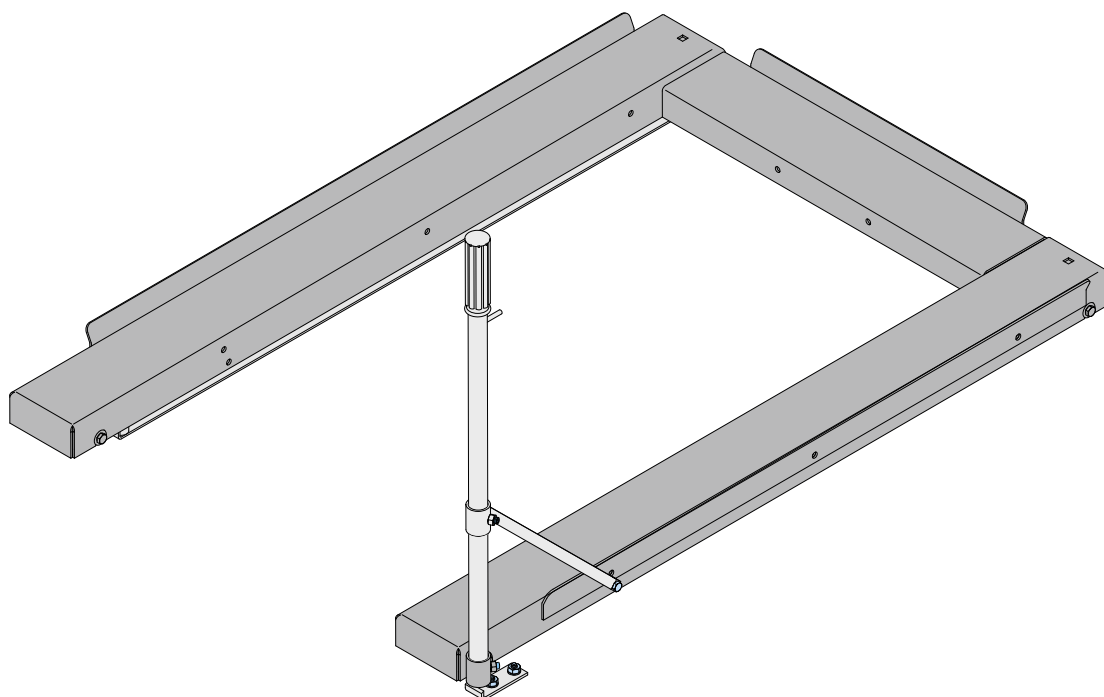
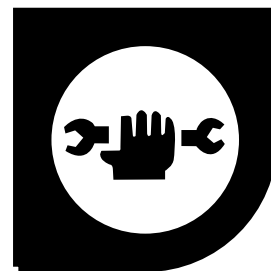

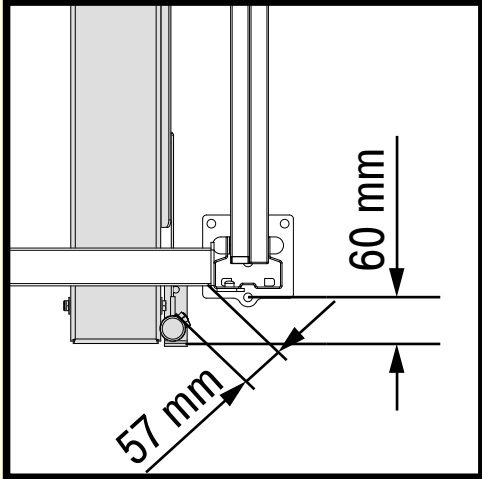
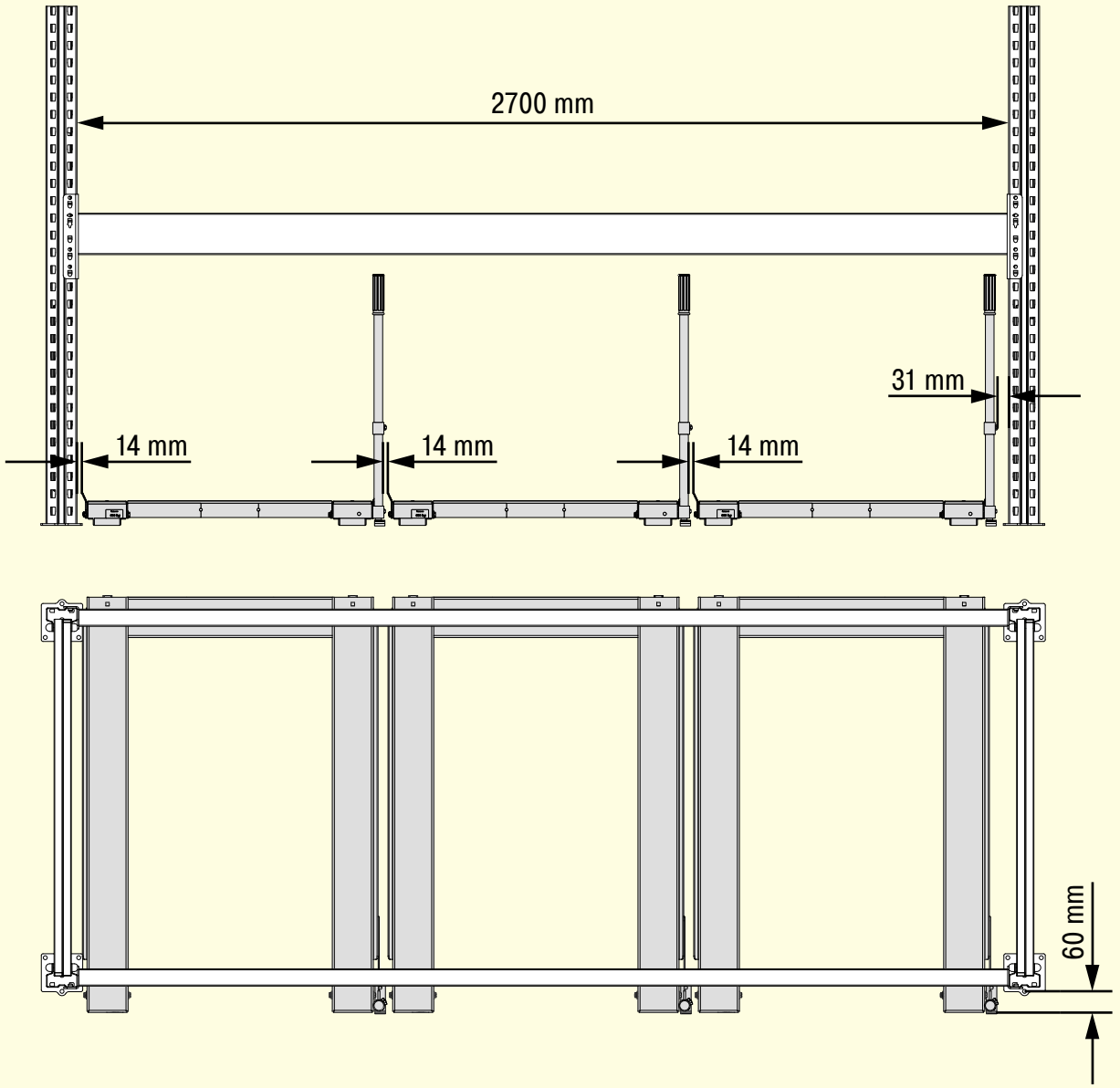

#33195 - 800 kg

M6-8.8	8 Nm	
M8-8.8	22 Nm	
M10-8.8	45 Nm	
M10-10.9	70 Nm	
M12-8.8	70 Nm	
M12-10.9	110 Nm	

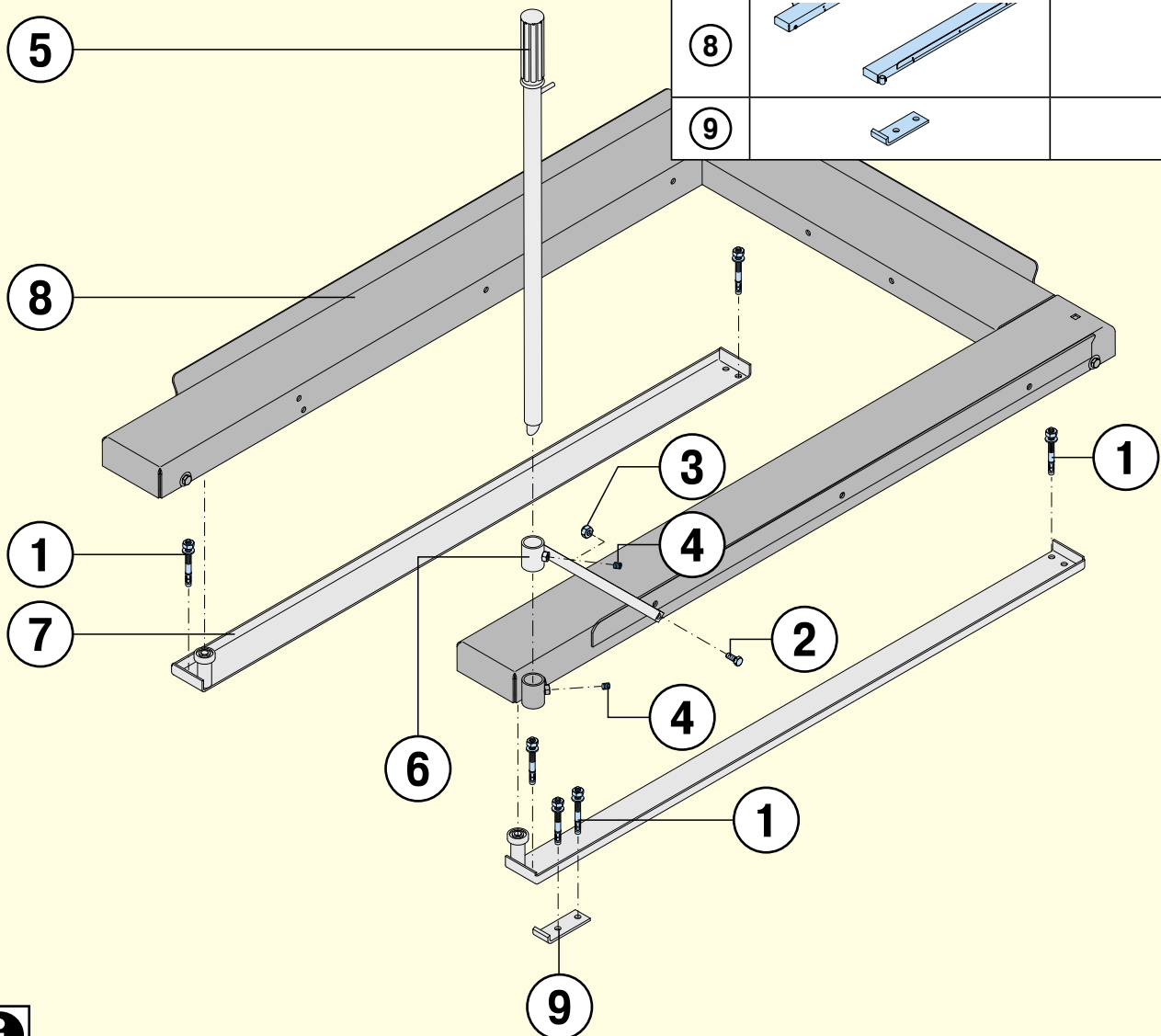

①			6x
②		8.8	1x
③			1x
④			2x
⑤			1x
⑥			1x
⑦			2x
⑧			1x
⑨			1x



AUSZUGSVORRICHTUNG | EXTRACTION UNITS

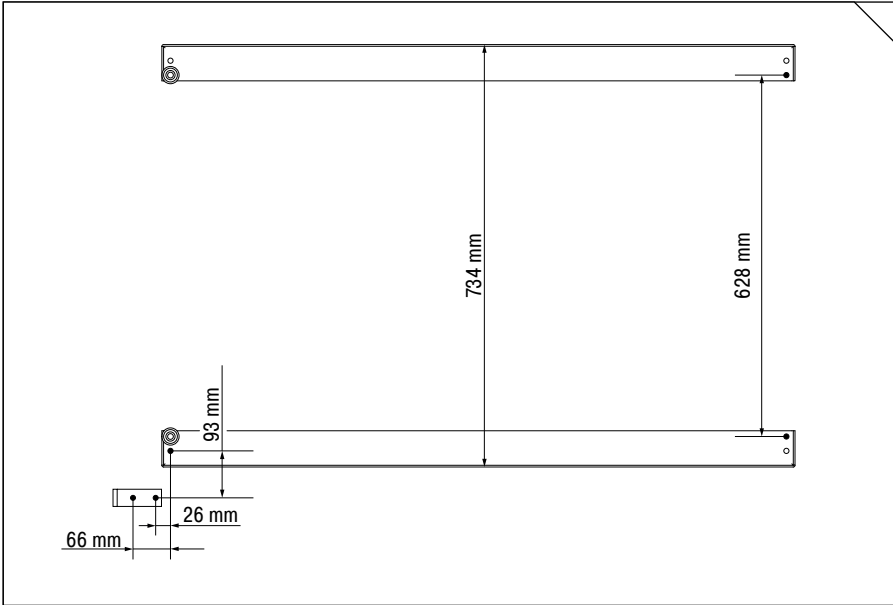

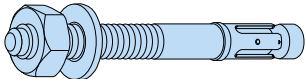

①	 M8	6x
⑦		2x
⑨		1x

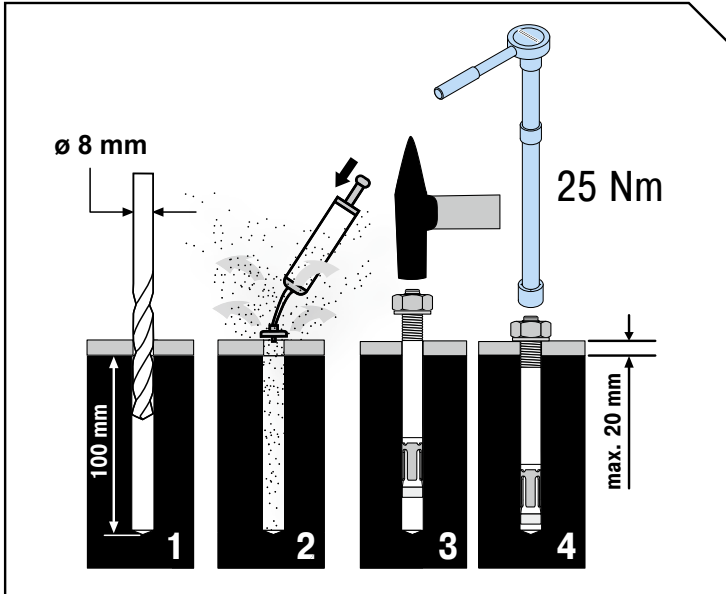
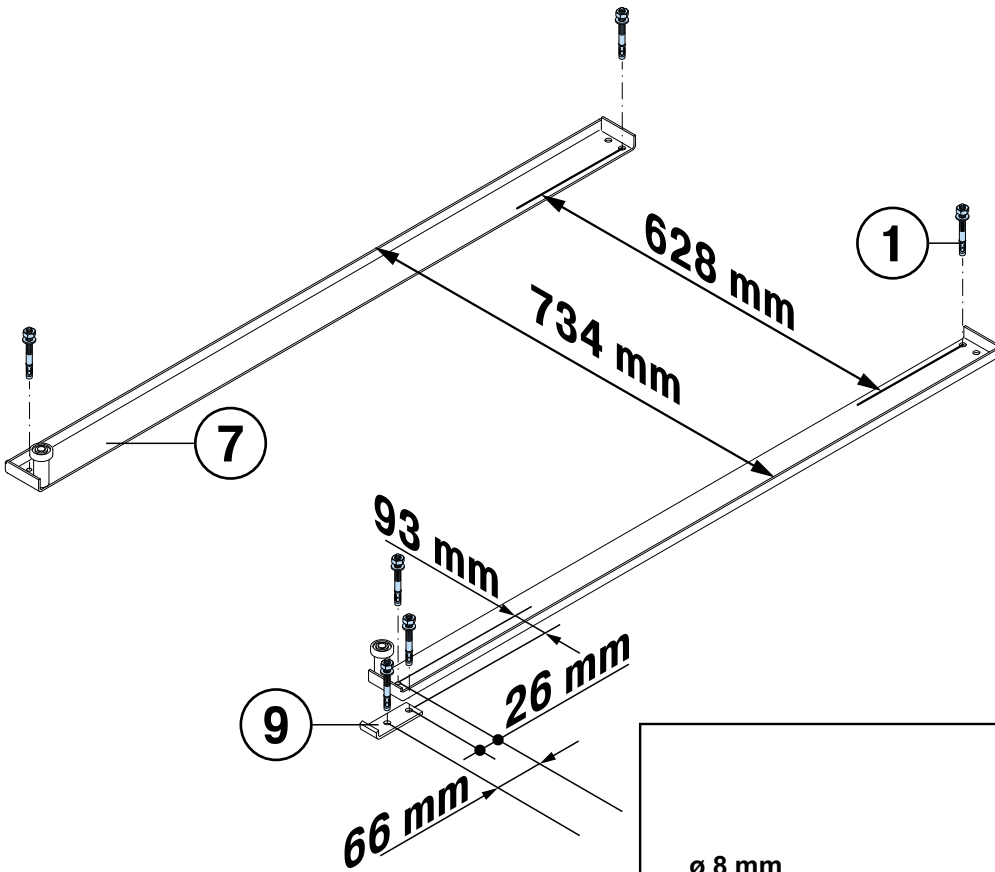



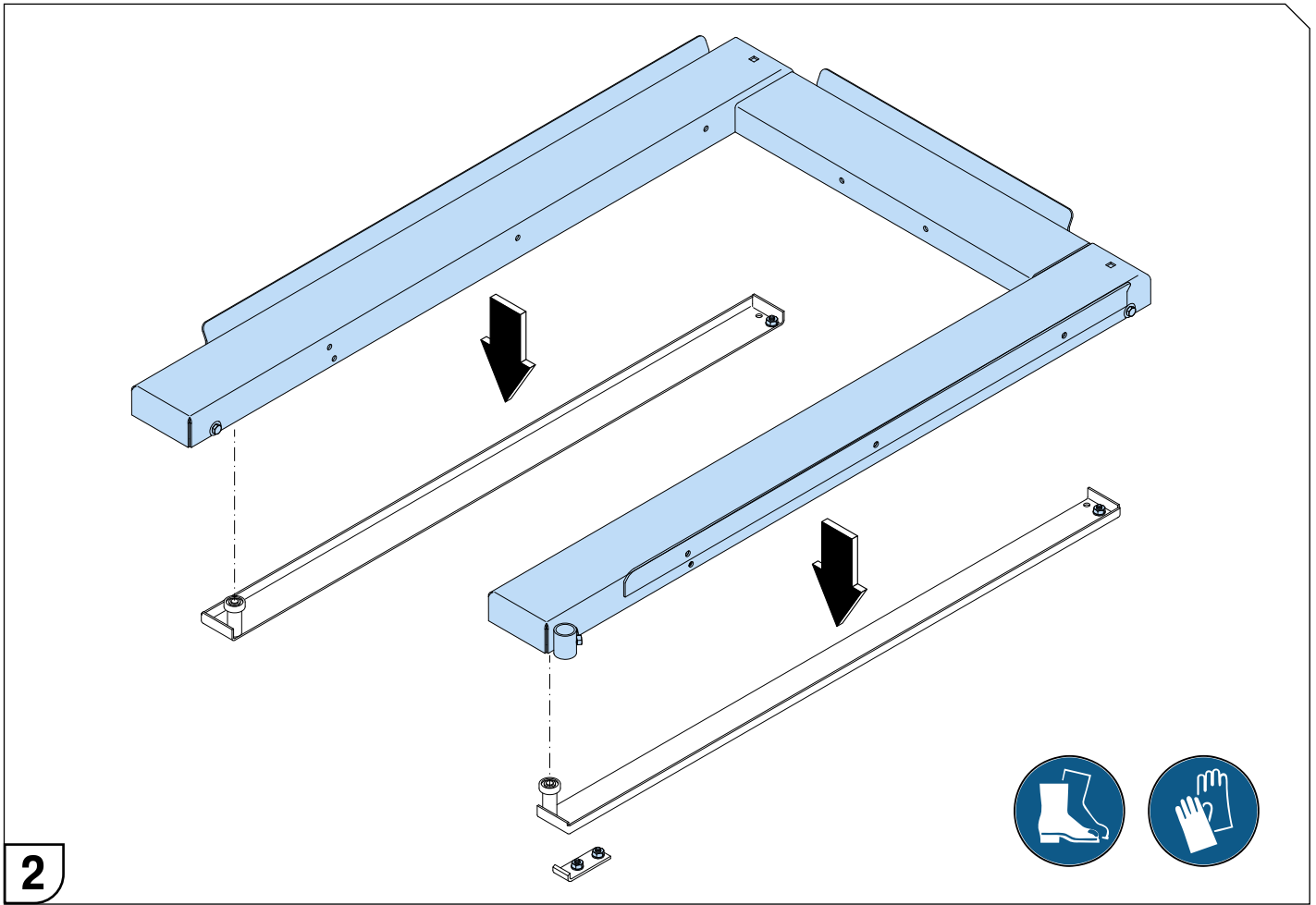

1

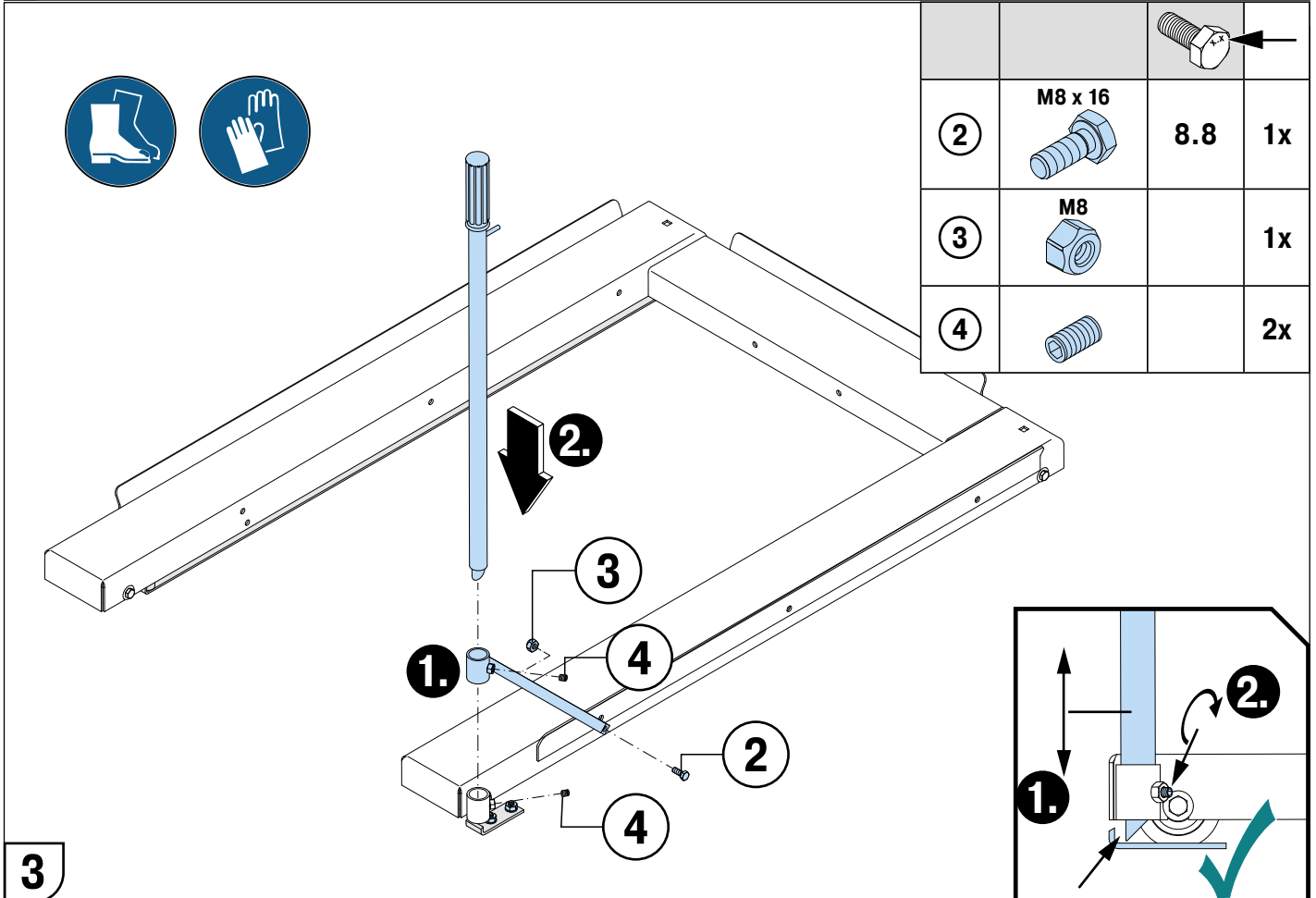

2

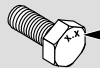

3

			
2	M8 x 16 	8.8	1x
3	M8 		1x
4			2x

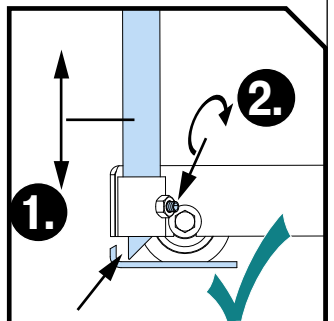

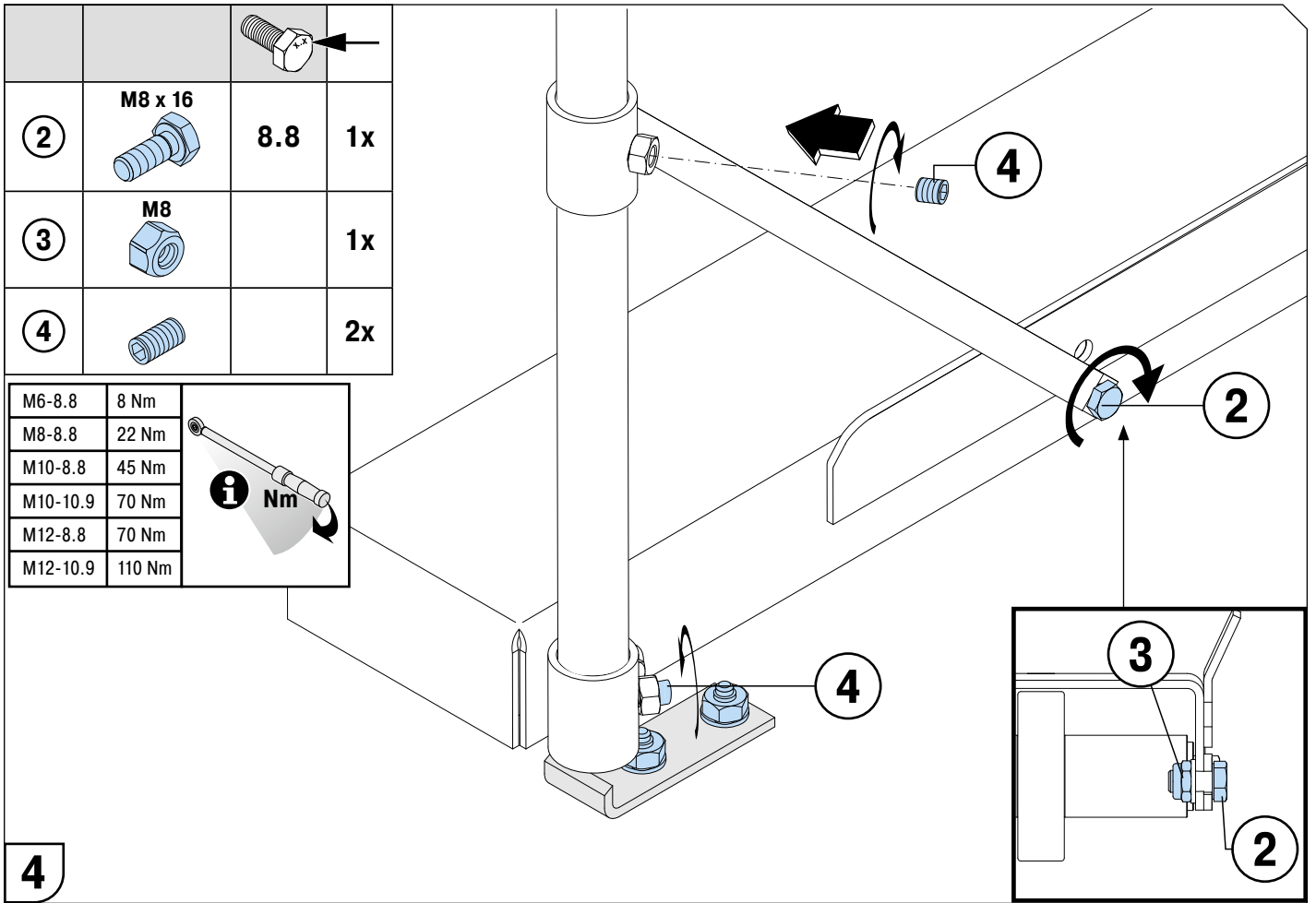

Auszugsvorrichtung

Extraction units

#33196 - 1000 kg

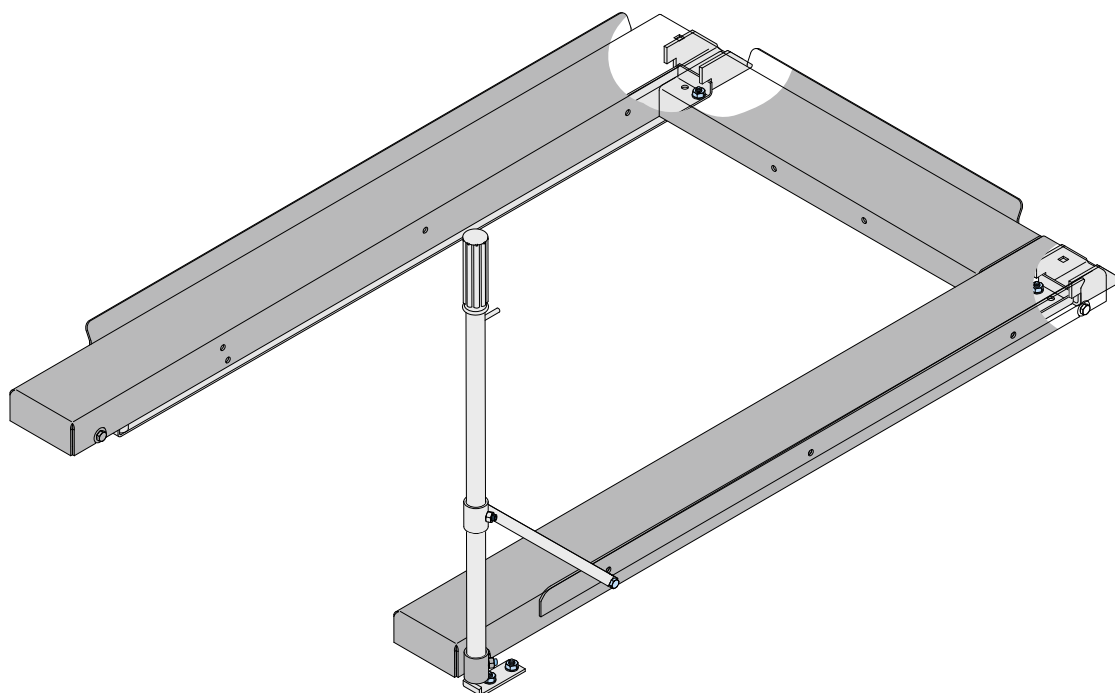
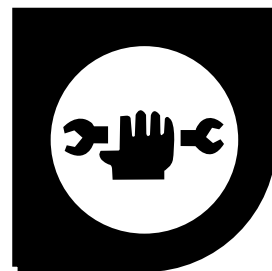

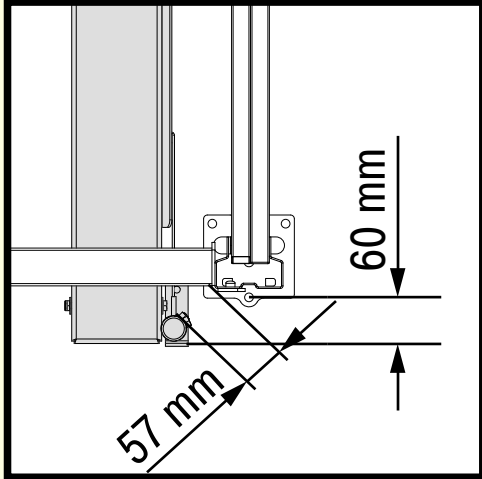
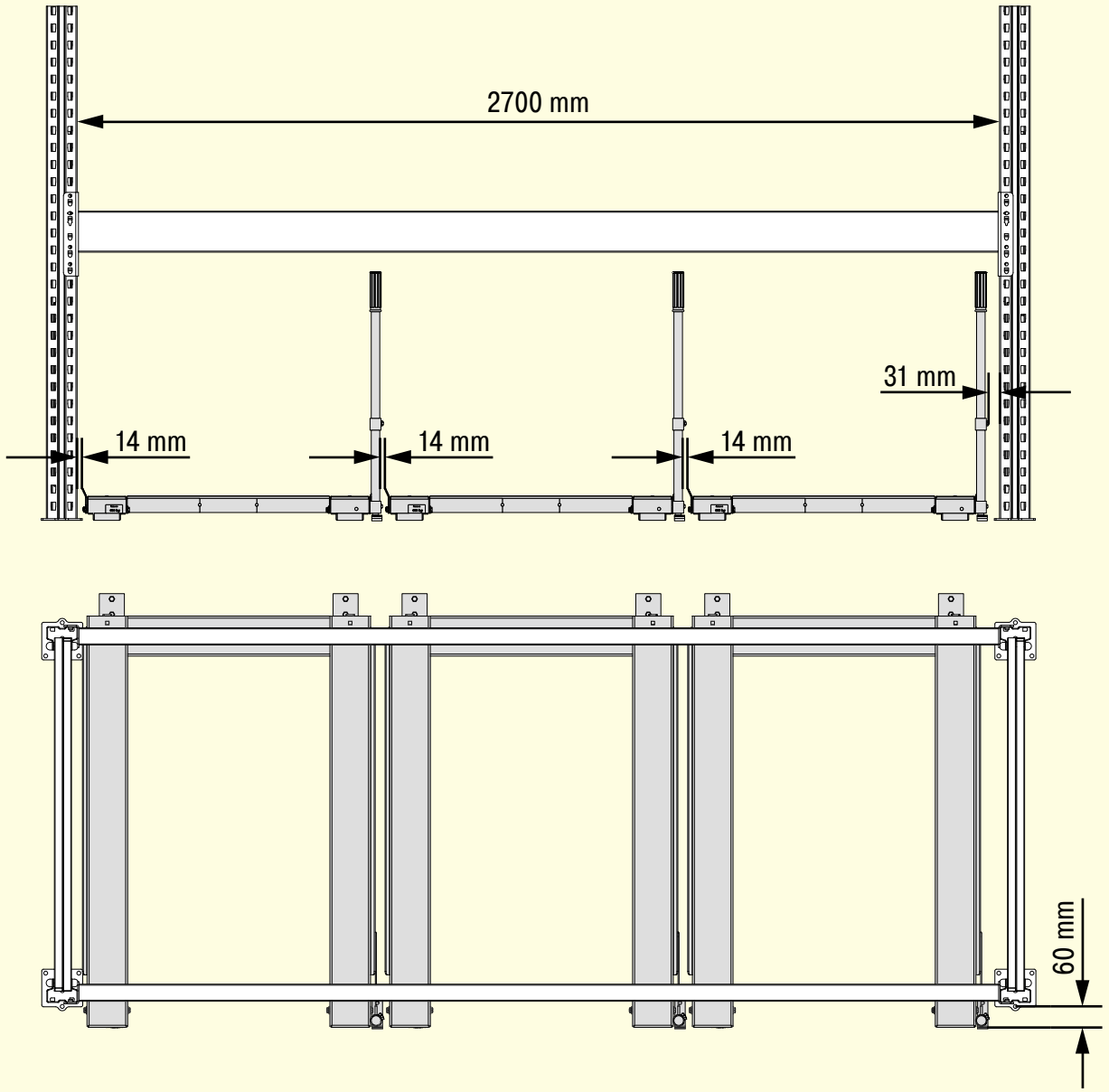

#33196 - 1000 kg

4 - 5 Nm

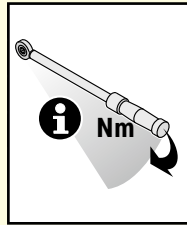

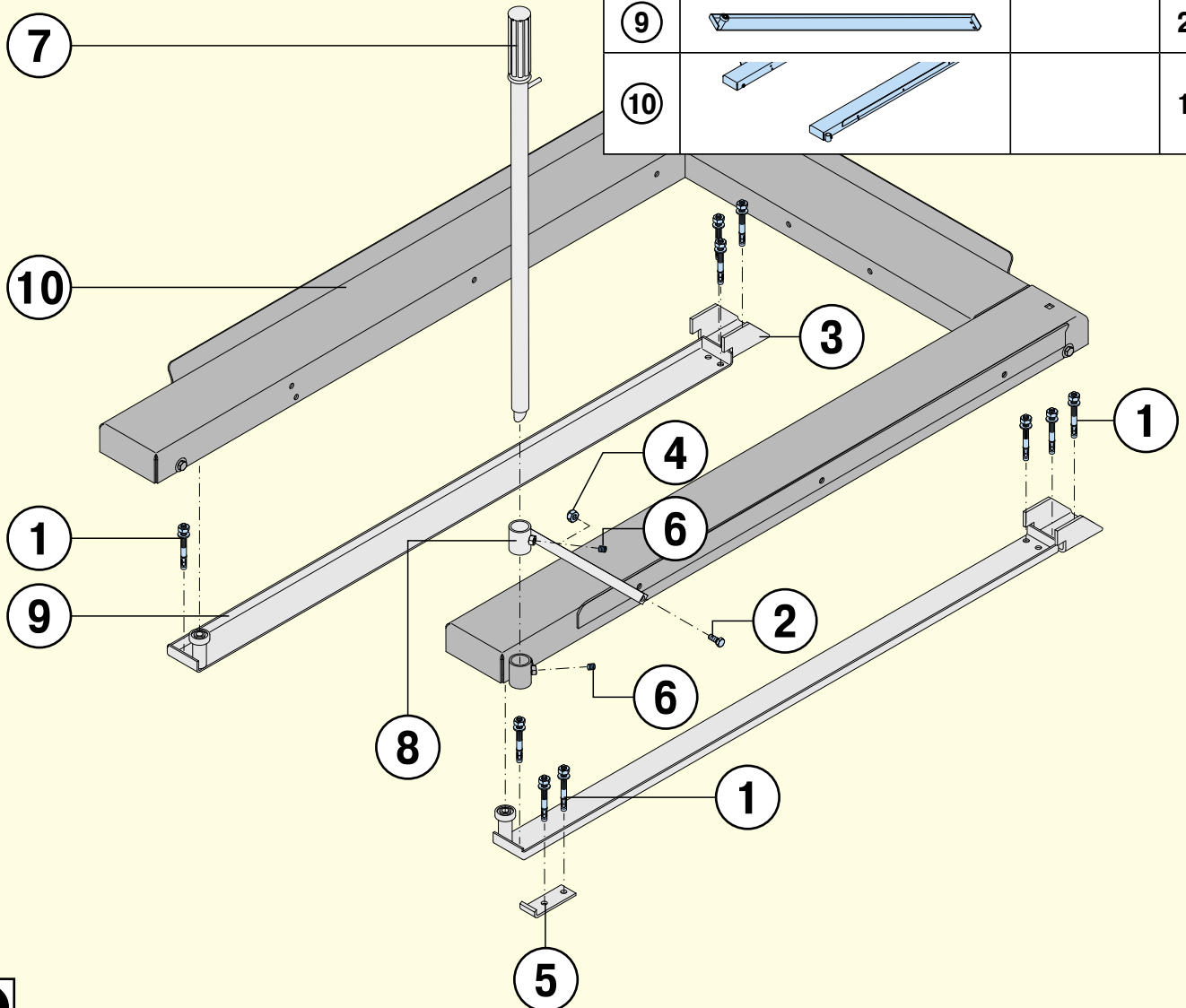

①		M8	10x
②		M8 x 16	8.8 1x
③			2x
④		M8	1x
⑤			1x
⑥			2x
⑦			1x
⑧			1x
⑨			2x
⑩			1x



AUSZUGSVORRICHTUNG | EXTRACTION UNITS

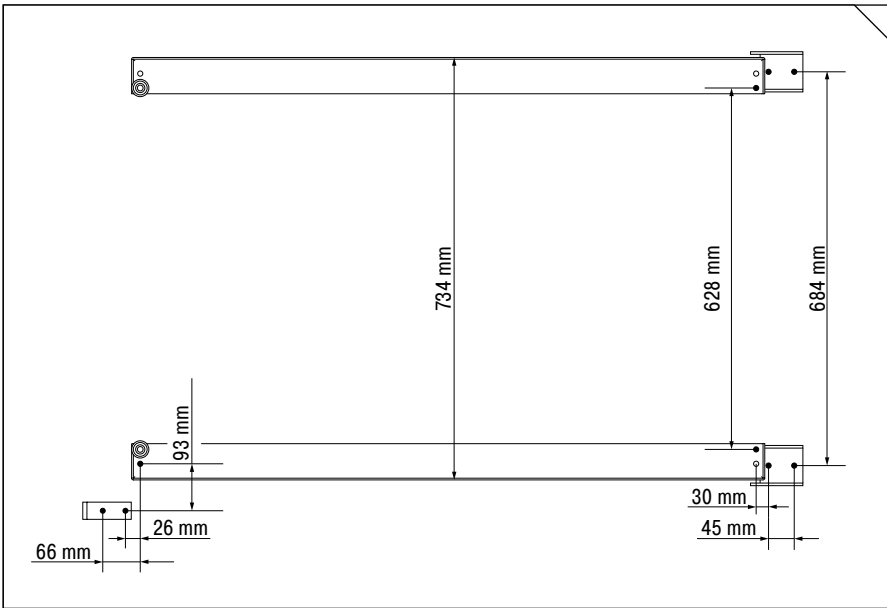

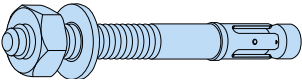

①	 M8	10x
⑨		2x
⑤		1x

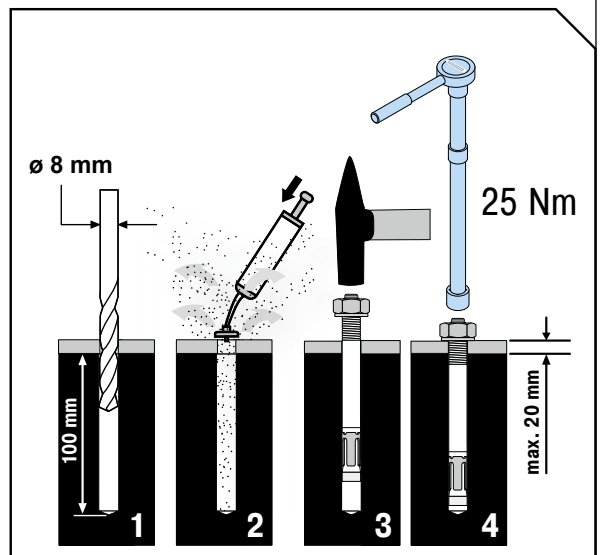
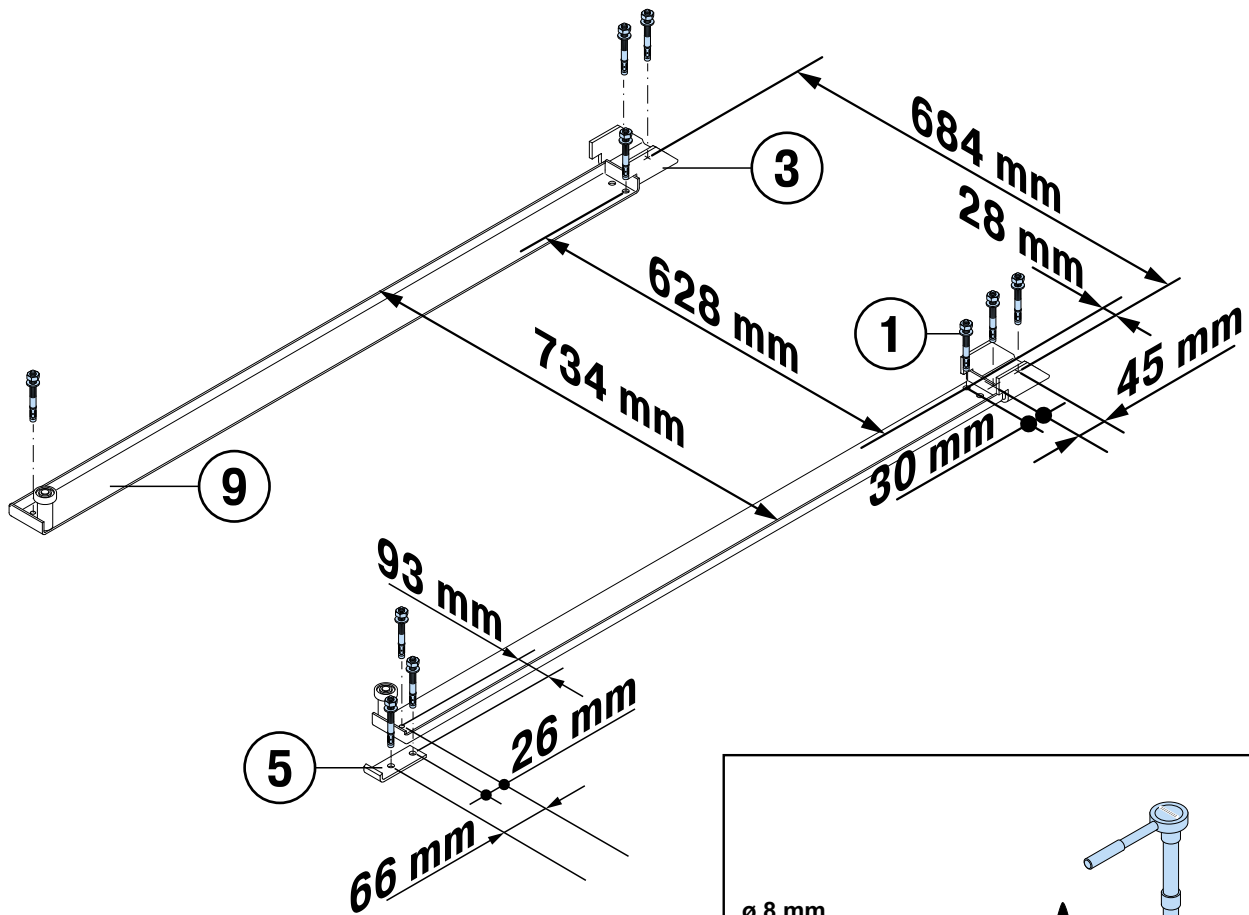

1

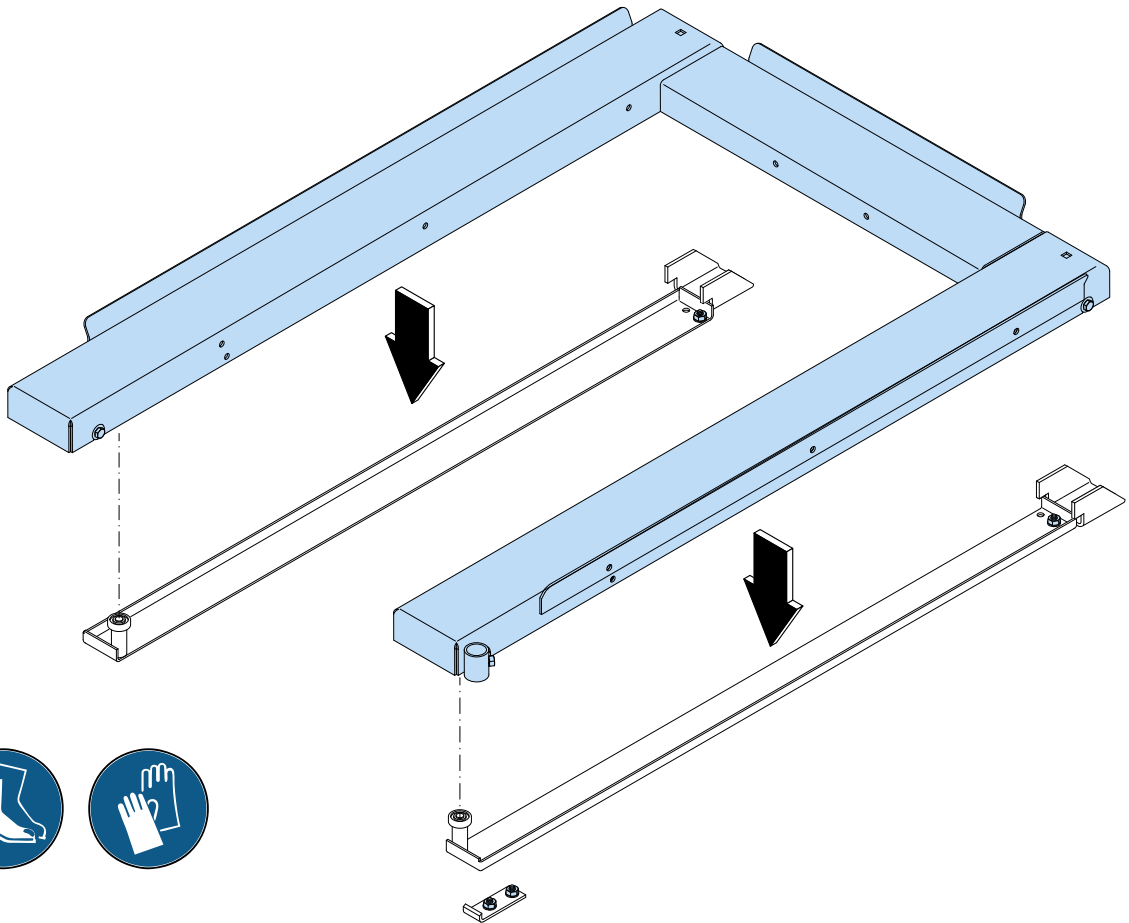

2

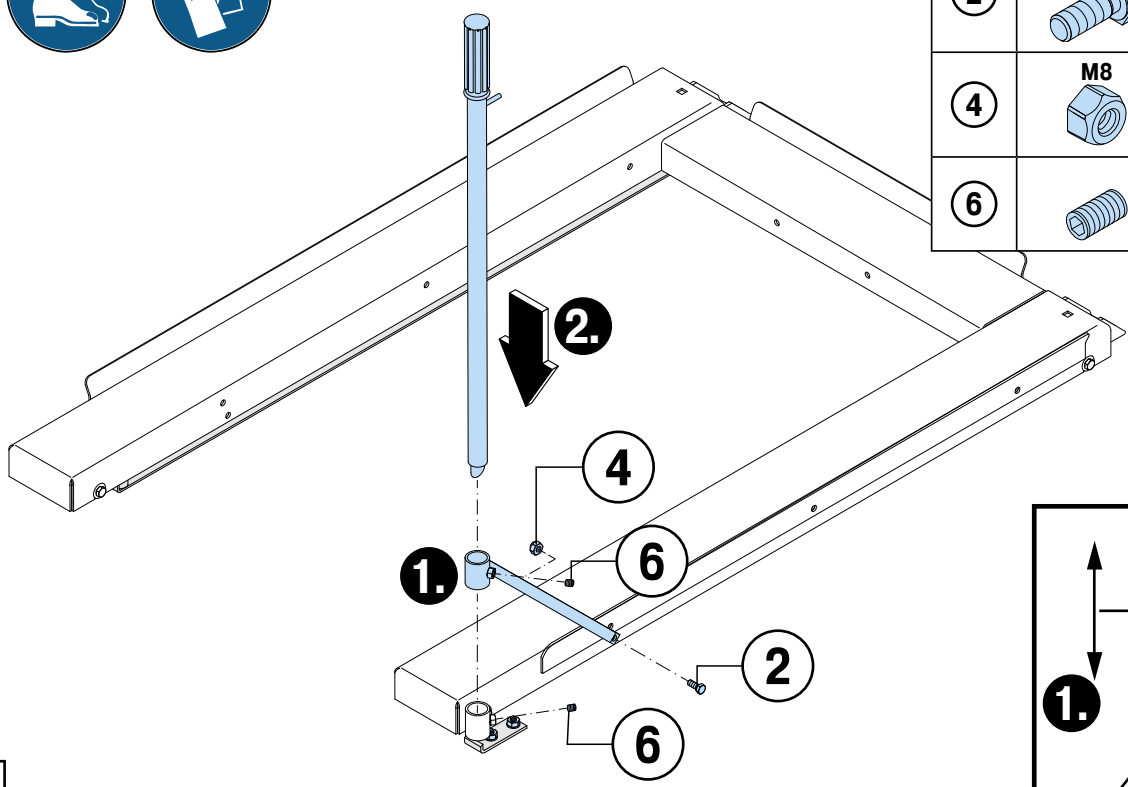

			←
②	M8 x 16		8.8 1x
④	M8		1x
⑥			2x

3

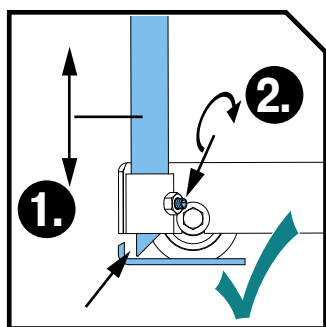

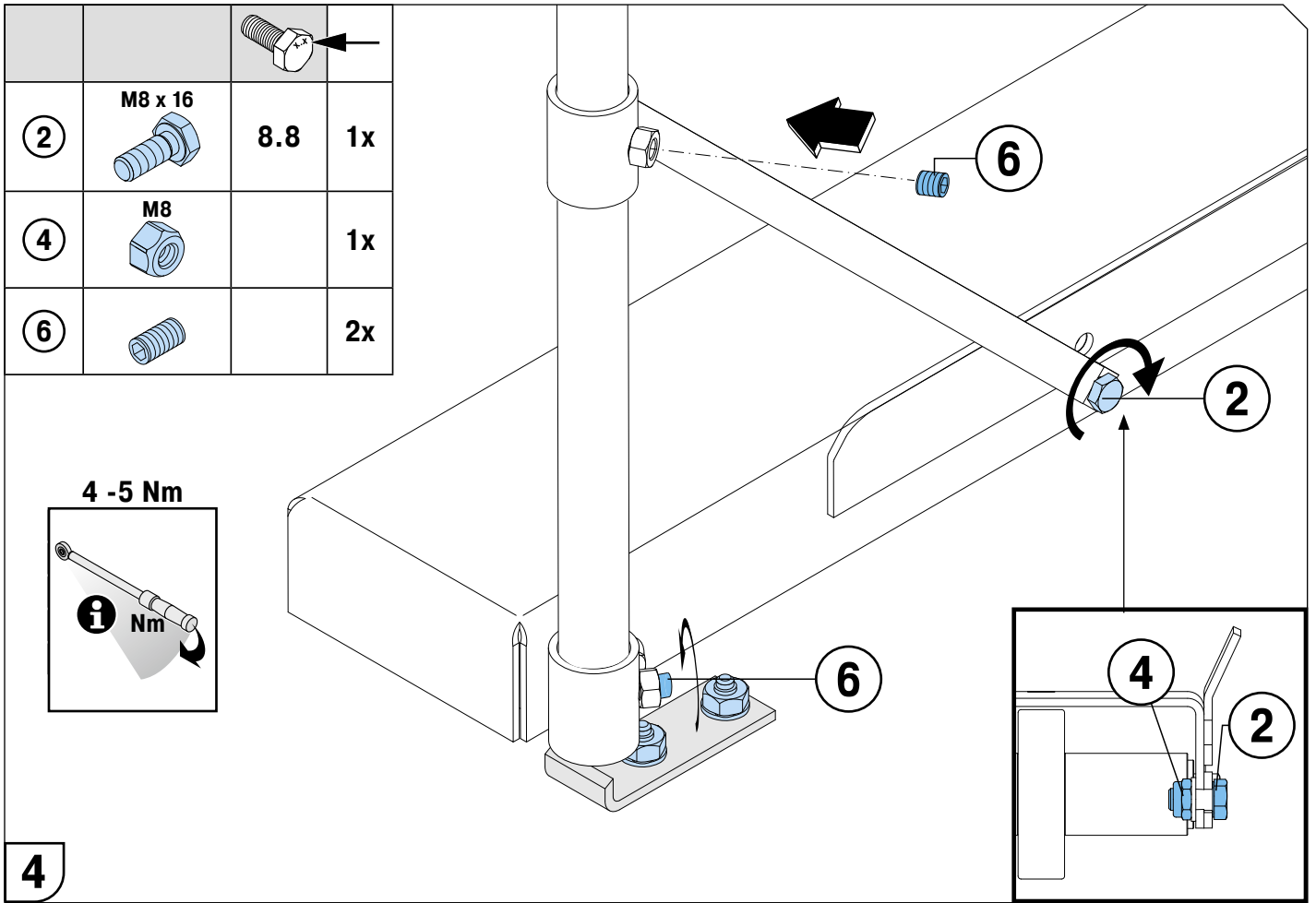

Auszugsvorrichtung

Extraction units

#33200 - 600 kg

#33201 - 800 kg

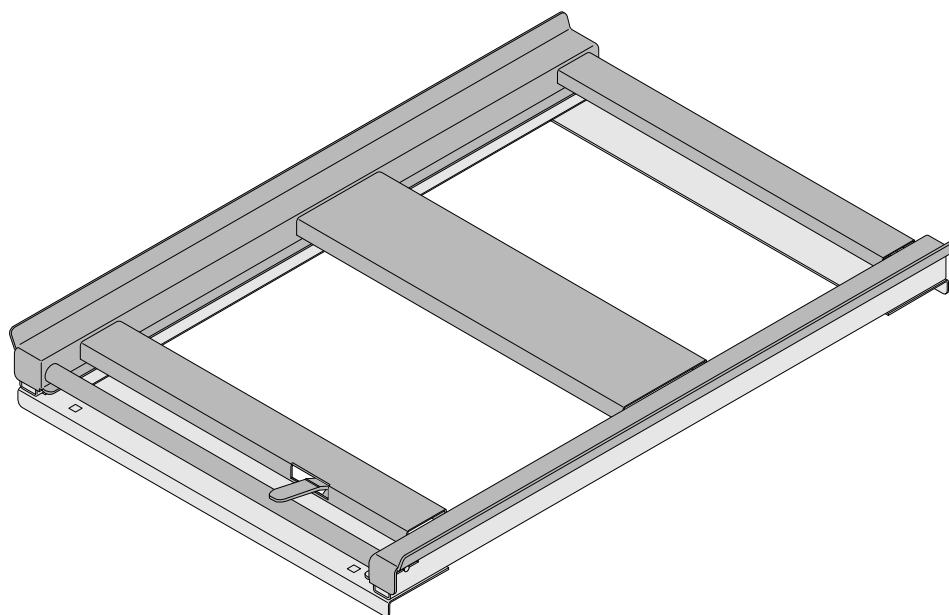
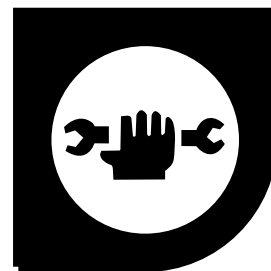

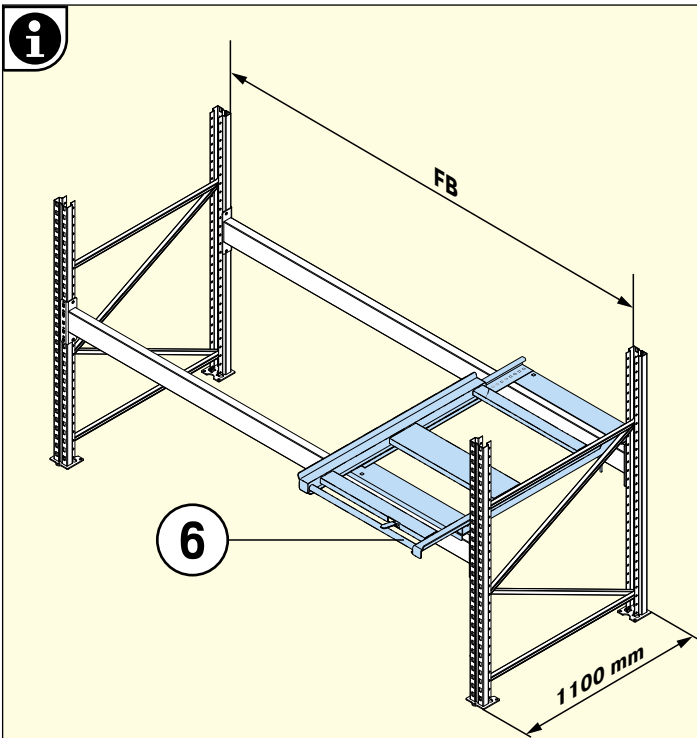

①	M8 x 160		8.8 4x
②	M8 x 200		8.8 4x
③	M8		6x
④	M8		6x
⑤	Platte 120 x 30 x 5		6x
⑥			1x
⑦	M8 x 20		8.8 4x
⑧	M10-20		8x

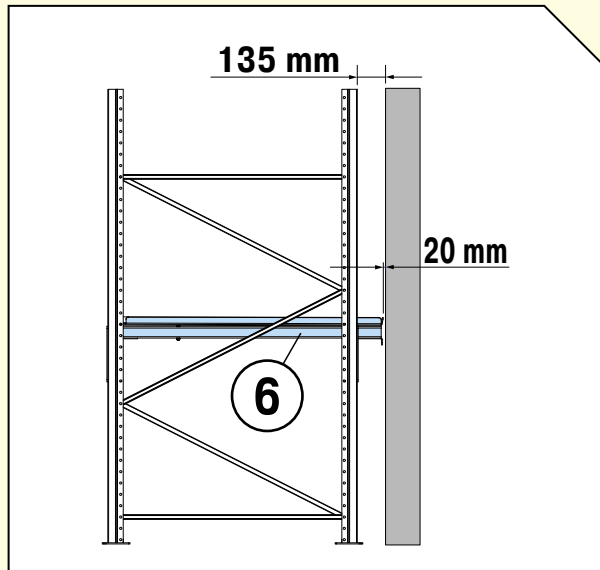
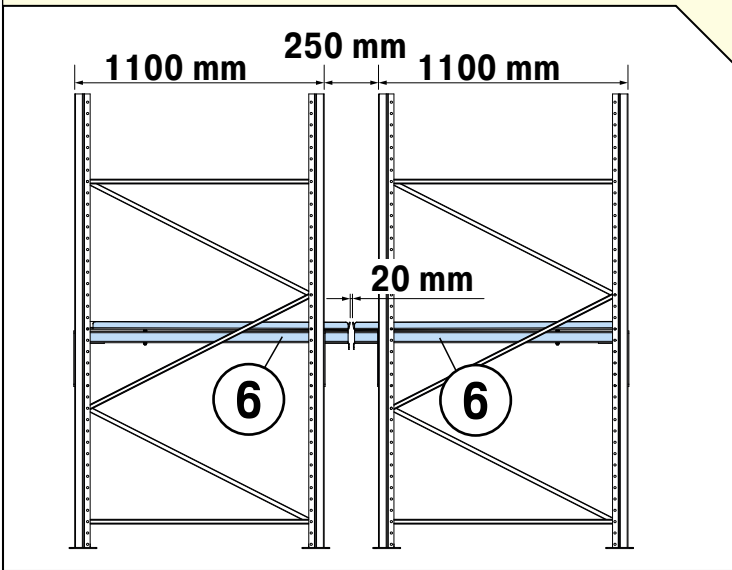

TK		Q (Fachlast/Level load)		
		FB = 950 mm	FB = 1800 mm	FB = 2700 mm
200 kg	A = 70 % T	510 kg	737 kg	964 kg
200 kg	A = 100 % T	643 kg	886 kg	1129 kg
300 kg	A = 100 % T	960 kg	1320 kg	1680 kg
600 kg	A = 70 % T	1476 kg	2112 kg	2748 kg
600 kg	A = 100 % T	1868 kg	2536 kg	3204 kg
800 kg	A = 70 % T	1974 kg	2828 kg	3682 kg
1000 kg	A = 70 % T	2488 kg	3576 kg	4664 kg
1000 kg	A = 100 % T	3098 kg	4196 kg	5294 kg

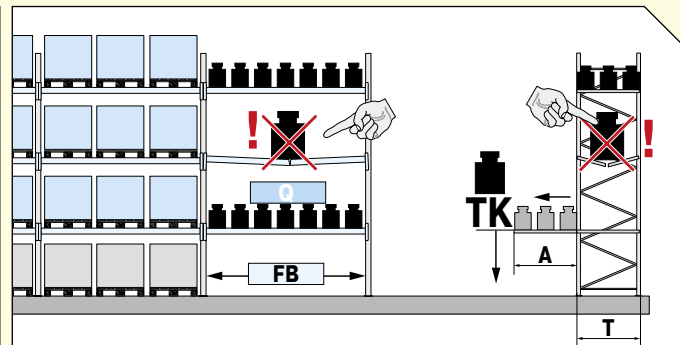

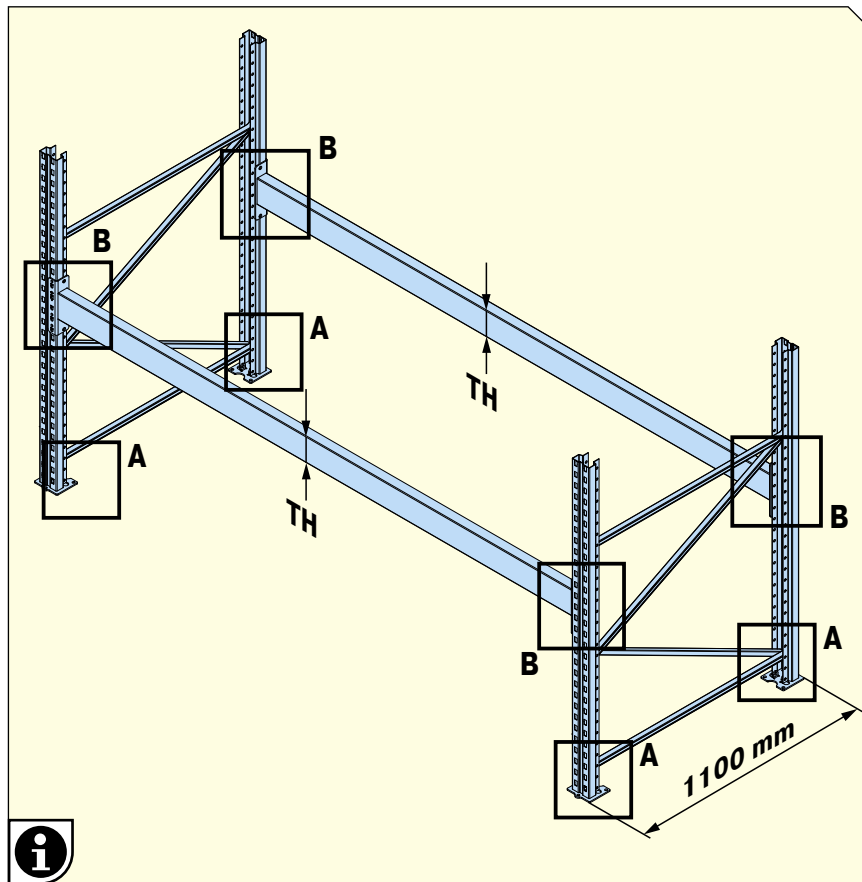

③	M8		6x
④	M8		6x
⑦	M8 x 20	8.8	4x
⑧	M10-20		8x

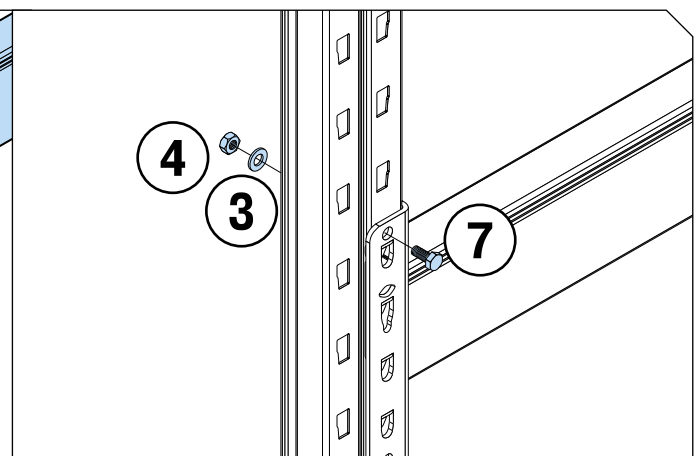
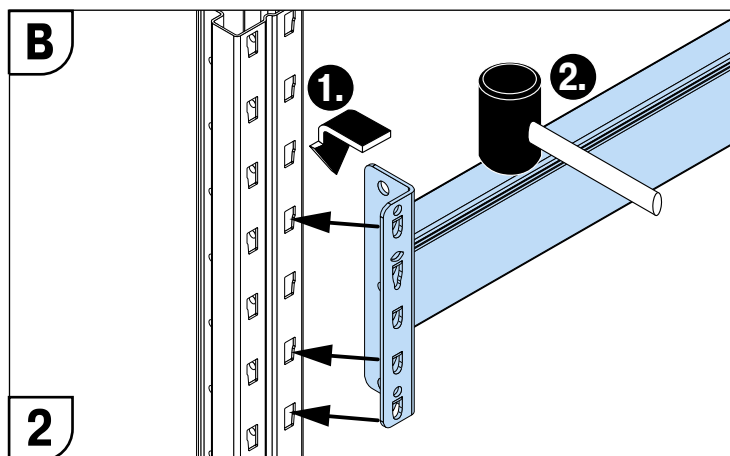
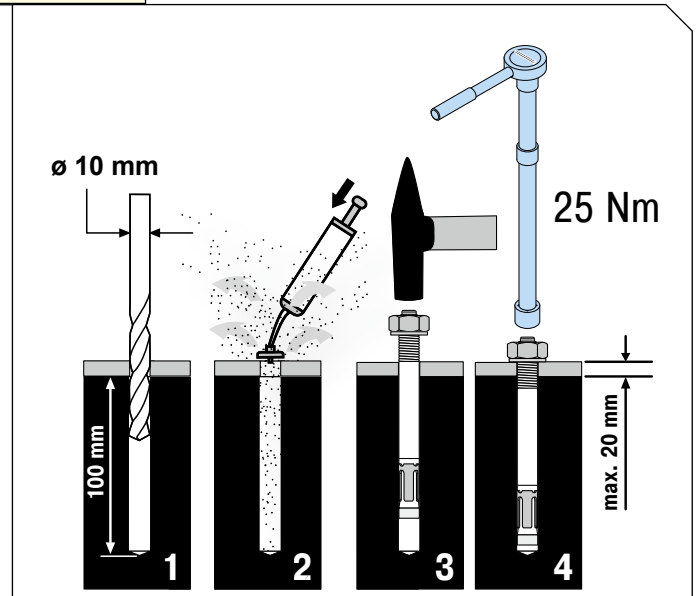
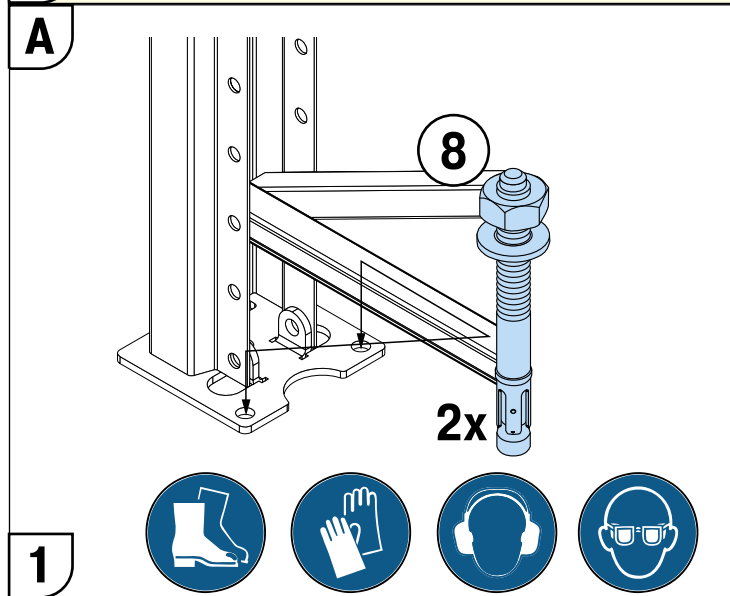

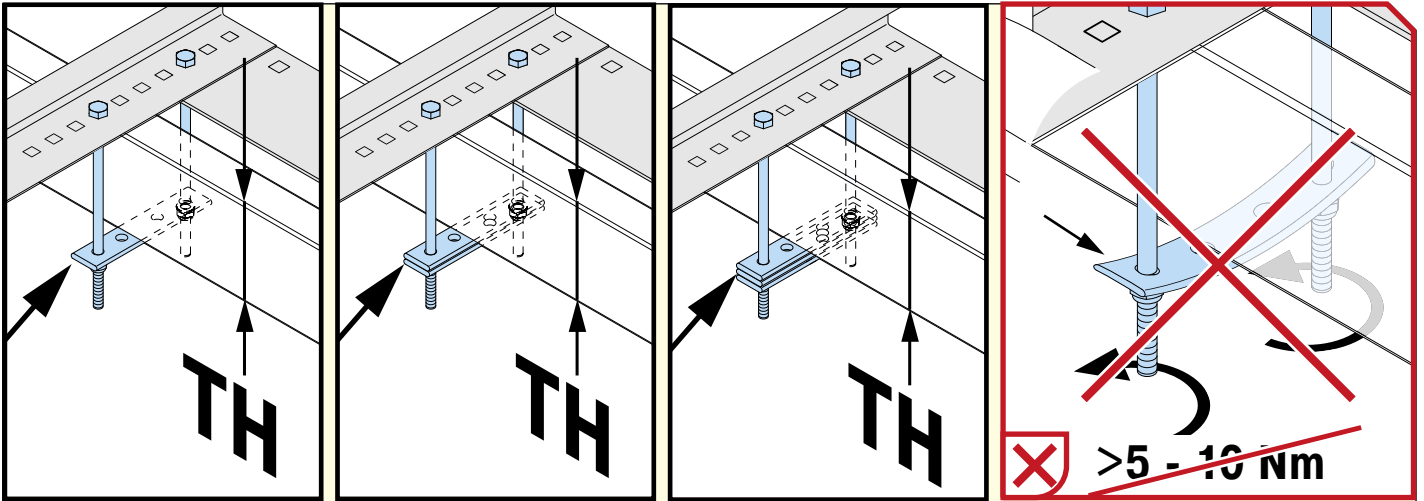

				TH
①	M8 x 160	8.8	4x	110 - 145 mm
②	M8 x 200	8.8	4x	145 - 170 mm

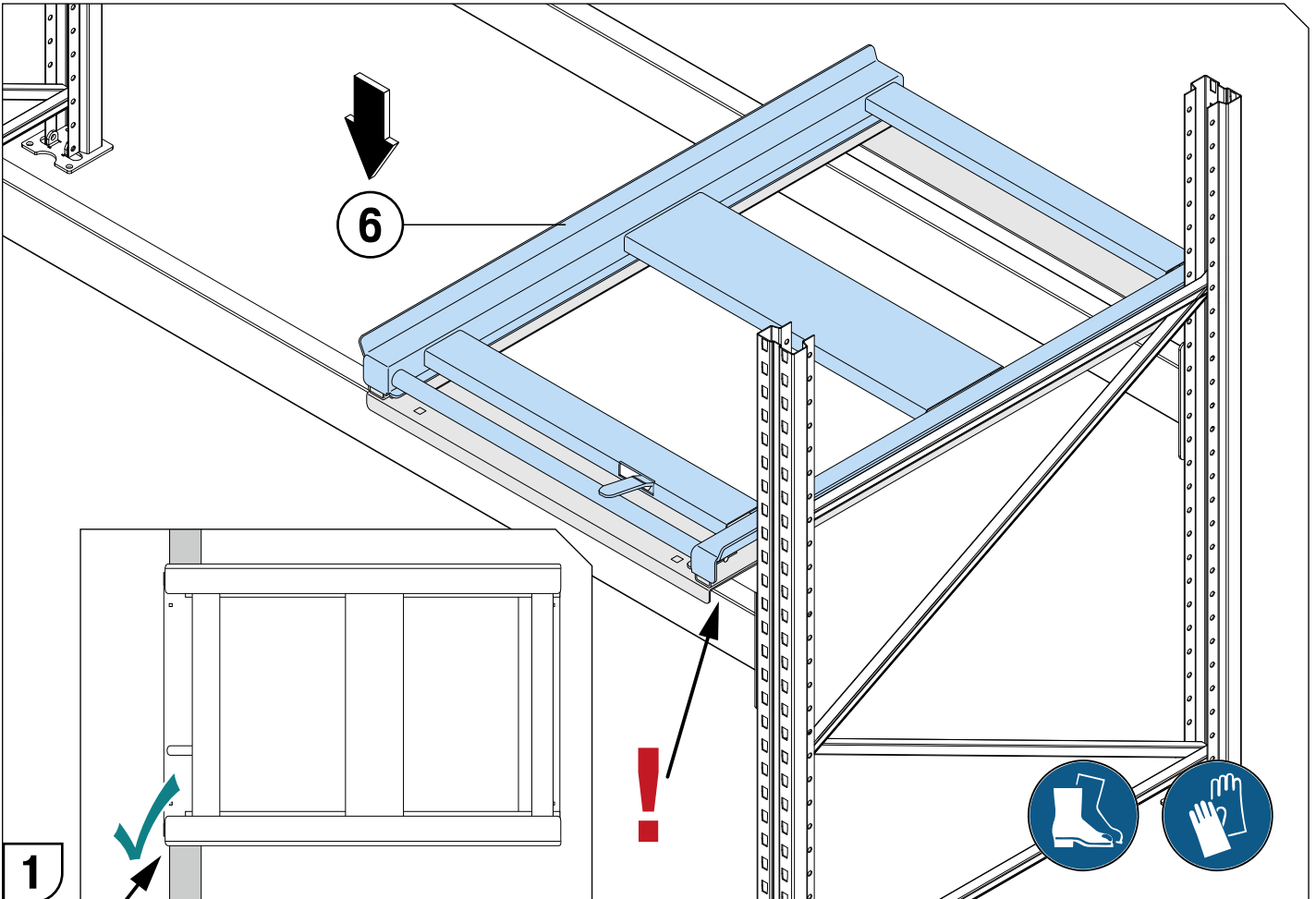
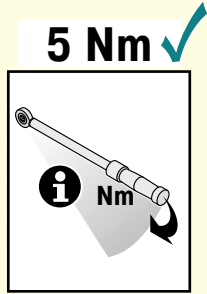

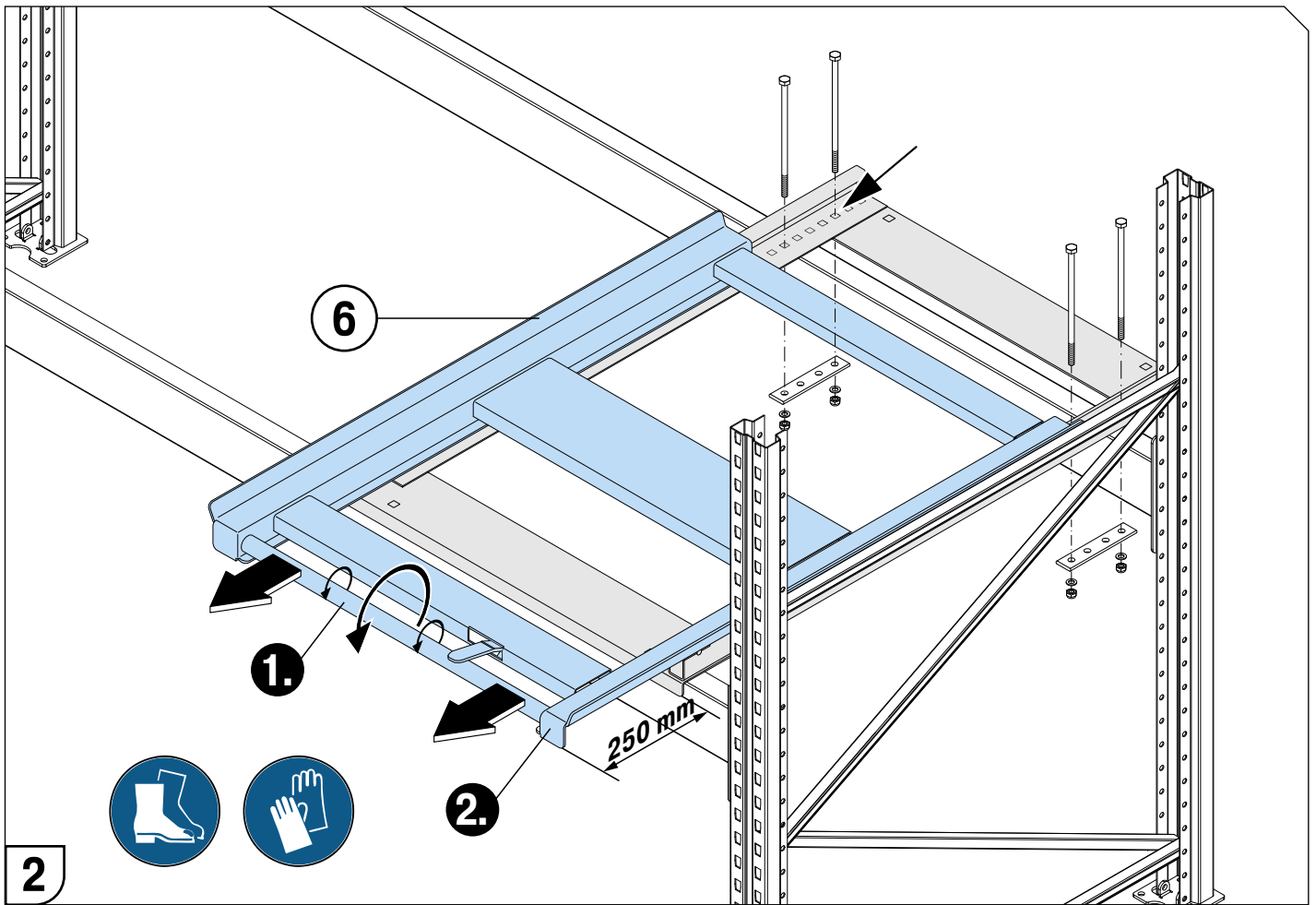

2

①	M8 x 160	8.8	4x
②	M8 x 200	8.8	4x
③	M8		4x
④	M8		4x
⑤	Platte 120 x 30 x 5		6x

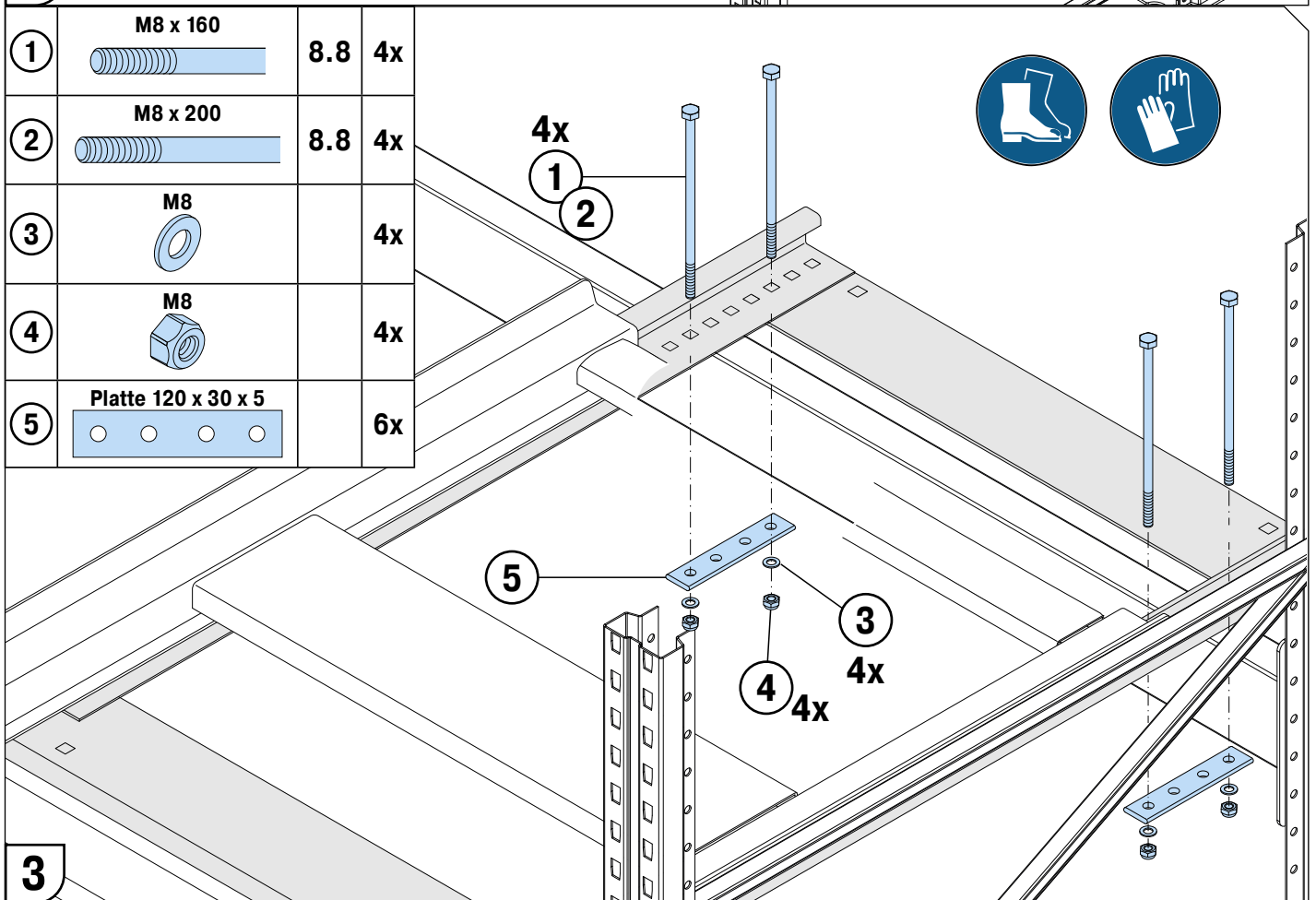

3

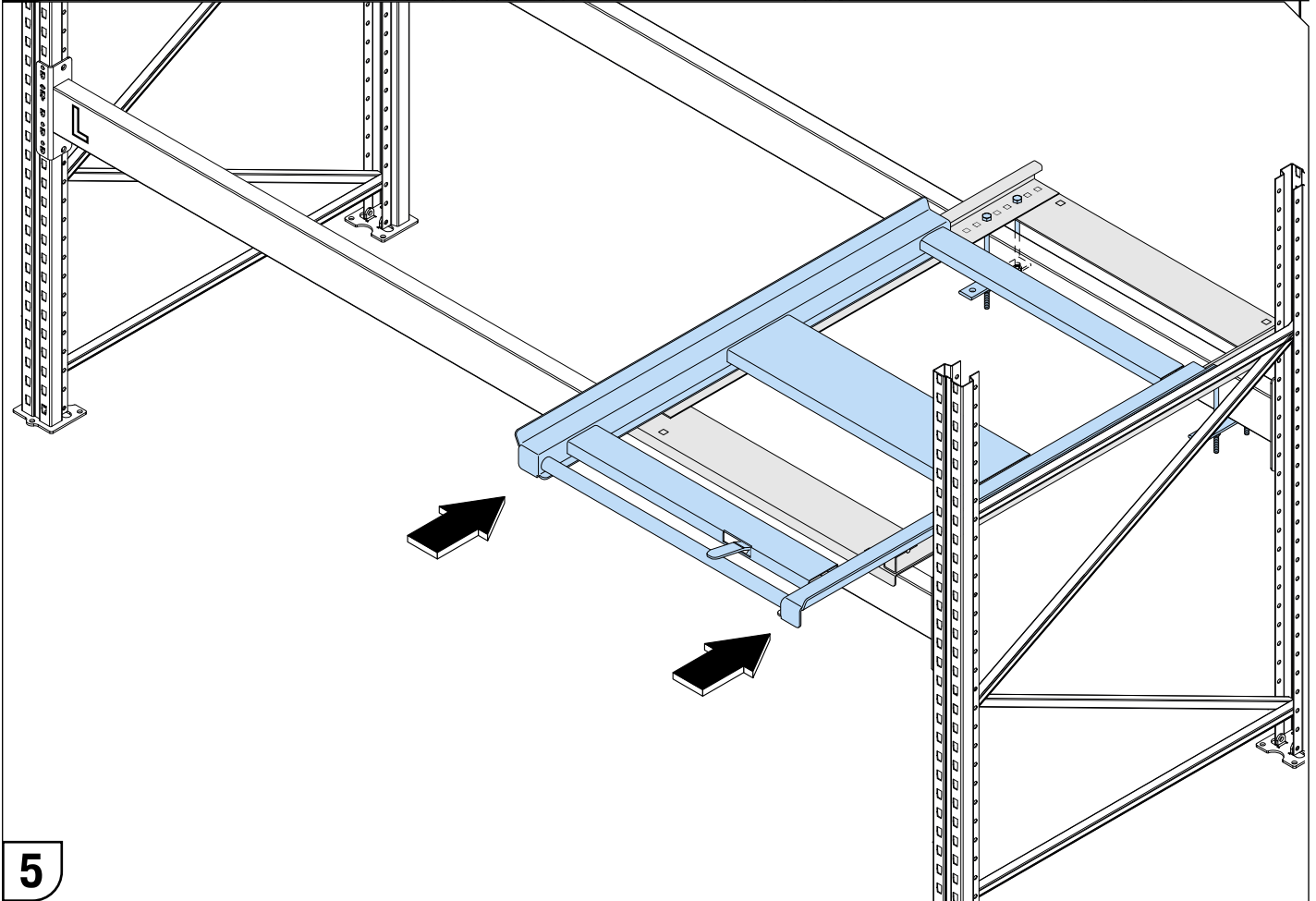
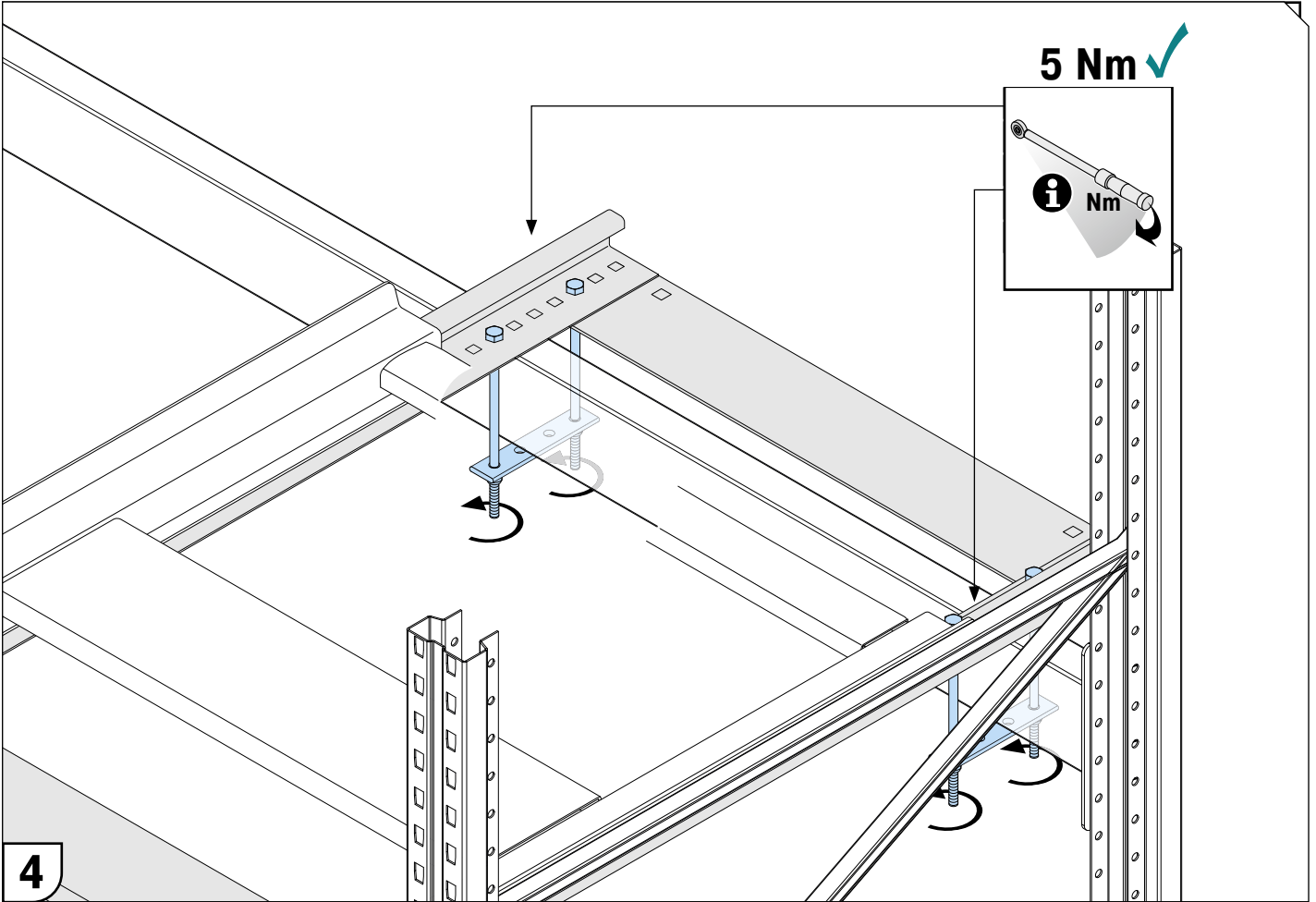

Auszugsvorrichtung

Extraction units

#10/2017/Art.-Nr.: 16454

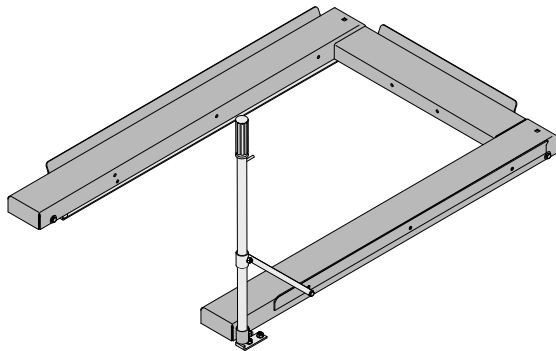

#33195 - 800 kg
#33196 - 1000 kg

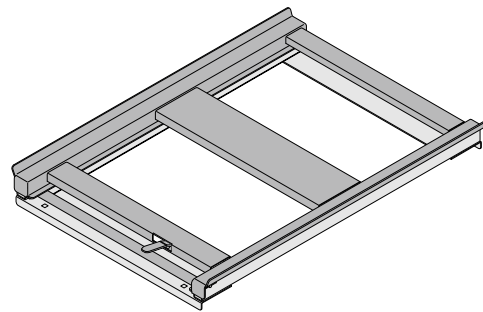

#33200 - 600 kg
#33201 - 800 kg

QR-Code



Wir freuen uns auf Ihr Feedback!
Looking forward to your feedback!

feedbackmontage@bito.com